

The ETP shaft bushing is a high-quality clamping element, which mounts components such as sprockets, toothed wheels, levers and other machine parts fast, easily and permanently onto shafts. Grooves, tapers and inside threads are no longer necessary.

Simply slide bushing and hub onto the shaft and tighten the few clamping screws. The only required tool is a simple hexagon wrench. However, a small torque wrench (up to 32 Nm) would be absolutely perfect. The transmissible torques easily exceed the allowable values of the shaft torsional stresses.

Here is an example for a shaft diameter of 40 mm with a feather key connection:

- a) Shaft material St 60 M_d approx. 230 Nm
- b) Shaft material 42 CrMo4 M_d approx. 310 Nm

The ETP bushing transmits 800 Nm (at 20° Centigrade). Since it is not necessary to mill grooves into the shaft, the shaft diameter can be reduced by max. 25 % (2 x groove depth), i.e. a shaft with a diameter of 30 mm fitted with the proper bushing transmits at least 340 Nm.

This means more efficiency due to:

1. Material savings
2. Lower dimensioning of other components, particularly bearings.

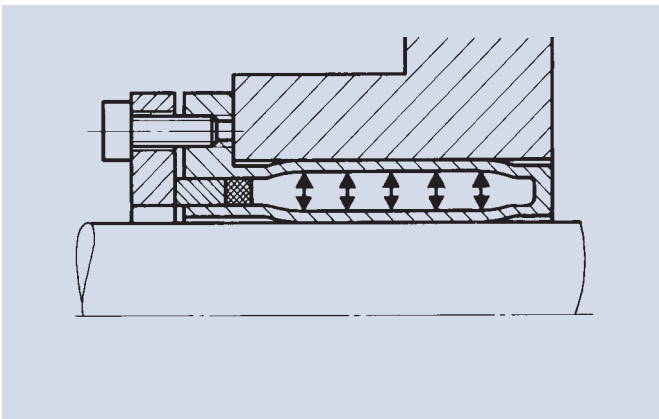

Fine adjustments are possible. Adjusting the transmission elements is never a problem. The bushings are subsequently radially and axially adjustable to change positions without difficulty and backlash-free.

The ETP bushing is easy to repair. There will be no frictional corrosion since micro-movements are prevented due to the solid connection. The bushing can always be re-used, e.g. it can easily be mounted to a new sprocket. Subsequent machining on the old shaft will not be necessary.

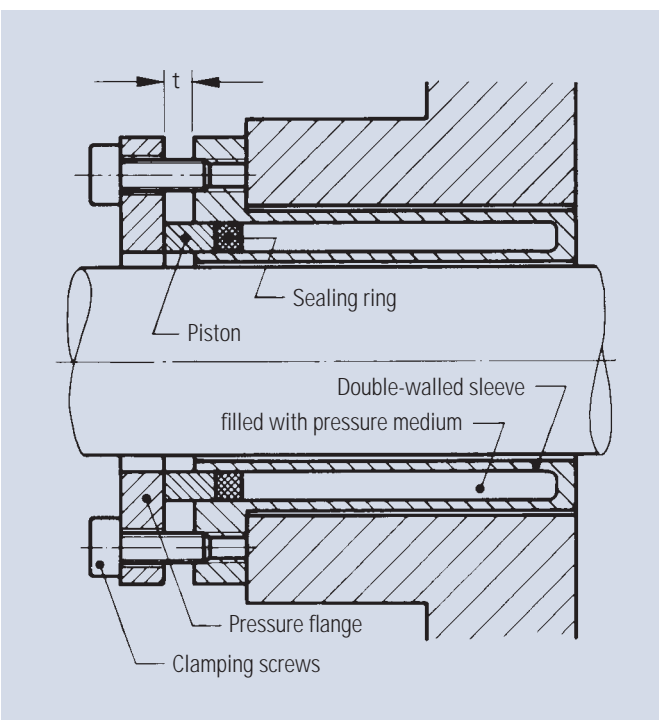

The ETP bushing consists of five parts: double-walled sleeve filled with pressure medium, sealing ring, piston, pressure flange and clamping screws (3, 4, 6 or 8 screws).

When the screws are being tightened, the piston forces the pressure medium in the double-walled sleeve against the walls. After tightening the screws with the required clamping torque M_{anz} , almost the entire bushing lies against shaft and hub. Thus the shaft and the respective part it is to be connected to are friction-locked. The pressure medium is resistant to material fatigue, and the clamping force of the bushing will persist. A 100 mm ETP bushing will then be non-slip up to a static moment of at least 12500 Nm. The maximum working temperature is 85°C.

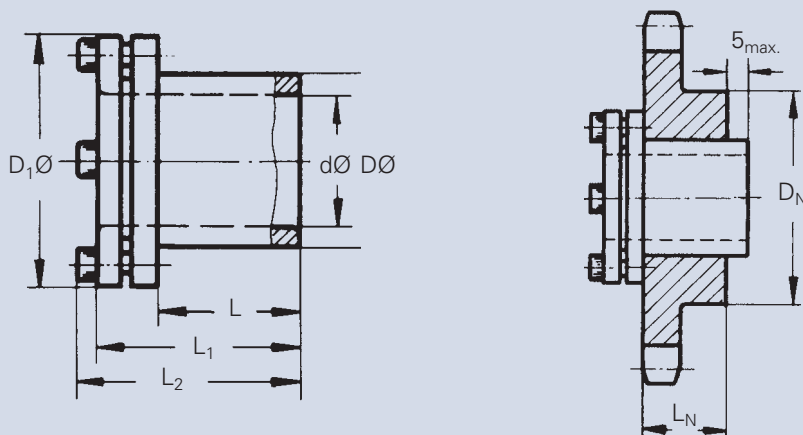

Order number	d	D	D ₁	L	L ₁	L ₂	M _N	F _N	Clamping screws			Weight	Hub Ø D _N min.		Hub length L _N
									Number	Thread	M _{anz.}		Steel	Cast iron	
	mm	mm	mm	mm	mm	mm	Nm	kN			Nm	kg	mm	mm	mm
ETP-15/23-17	15	23	36	17	28	32	43	5,7	3	M4	4,5	0,11	35	46	12
ETP-19/28-21	19	28	45	21	34	39	88	9,3	3	M5	7	0,18	42	56	16
ETP-20/28-22	20	28	45	22	40	45	125	13,0	3	M5	8	0,18	42	56	22
ETP-22/32-22	22	32	49	22	35	40	135	11,6	3	M5	8	0,21	48	64	17
ETP-24/34-25	24	34	49	25	38	43	175	14,4	4	M5	8	0,22	51	68	20
ETP-25/34-27	25	34	49	27	41	46	195	16,2	4	M5	8	0,22	51	68	22
ETP-28/39-29	28	39	55	29	43	48	280	19,5	4	M5	8	0,28	59	78	24
ETP-30/41-32	30	41	57	32	46	51	340	23,1	4	M5	8	0,30	62	82	27
ETP-32/43-34	32	43	60	34	50	55	410	26,1	4	M5	8	0,34	65	86	29
ETP-35/47-37	35	47	63	37	53	58	540	31,1	6	M5	8	0,40	71	94	32
ETP-38/50-41	38	50	65	41	57	62	700	37,4	6	M5	8	0,46	75	100	36
ETP-40/53-43	40	53	70	43	60	65	800	41,3	6	M5	8	0,58	80	106	38
ETP-42/55-45	42	55	70	45	62	67	940	45,4	6	M5	8	0,60	83	110	40
ETP-45/59-49	45	59	77	49	66	72	1180	53,0	6	M6	13	0,75	89	118	44
ETP-48/62-52	48	62	80	52	70	76	1370	59,9	6	M6	13	0,80	93	124	47
ETP-50/65-53	50	65	83	53	72	78	1620	64,8	6	M6	13	0,93	98	130	48
ETP-55/71-58	55	71	88	58	77	83	2110	77,9	8	M6	13	1,10	107	142	53
ETP-60/77-64	60	77	95	64	85	91	2750	93,6	8	M6	13	1,40	116	154	59
ETP-65/84-68	65	84	102	68	90	96	3430	108	8	M6	13	1,73	126	168	63
ETP-70/90-72	70	90	113	72	94	100	4300	124	6	M8	32	1,90	135	180	67
ETP-75/95-85	75	95	118	85	108	114	5300	153	6	M8	32	2,25	143	190	80
ETP-80/100-90	80	100	123	90	114	122	6400	173	6	M8	32	2,62	150	200	85
ETP-85/106-95	85	106	129	95	119	127	7700	194	6	M8	32	3,00	159	212	90
ETP-90/112-100	90	112	135	100	127	135	9100	216	8	M8	32	3,56	168	224	95
ETP-95/120-105	95	120	143	105	132	140	10700	239	8	M8	32	4,39	180	240	100
ETP-100/125-110	100	125	148	110	139	147	12500	264	8	M8	32	4,81	188	250	105

Dimensions, technical specifications and other details were correct at the time of printing, but are subject to change. M_{anz} is the clamping torque of the clamping screws to reach M_N or F_N . F_N is the transmissible axial force at a torque of 0. M_N is the transmissible torque at an axial force of 0.

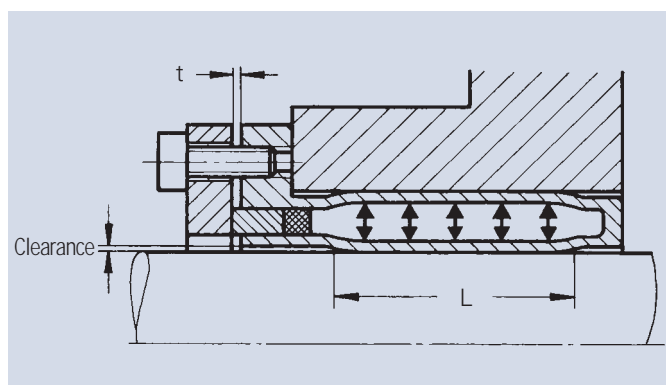

Fit tolerances

ETP bushings have been designed for the following fit tolerances:

Shafts \varnothing h8 – k6 (except 15 mm \varnothing : h7), hub bore hole H7.
Permissible roughness depth: $R_a \text{ max} = 3 / R_a \text{ min.} = 1$ [μm].

Please note: the torque transmission (M) is influenced in a negative way, if the tolerance zone of the bushing connection does not comply with the recommended values. The distance (t) will diminish with increasing clearance. In case of exceedingly high tolerances the pressure flange will connect to the sleeve without the surface pressure required for the torque transmission being reached.

Hub dimensioning

Depending on the material used, the pressure reached at the maximum clamping torque requires a minimum wall thickness of the hub as well as a minimum hub length (see table).