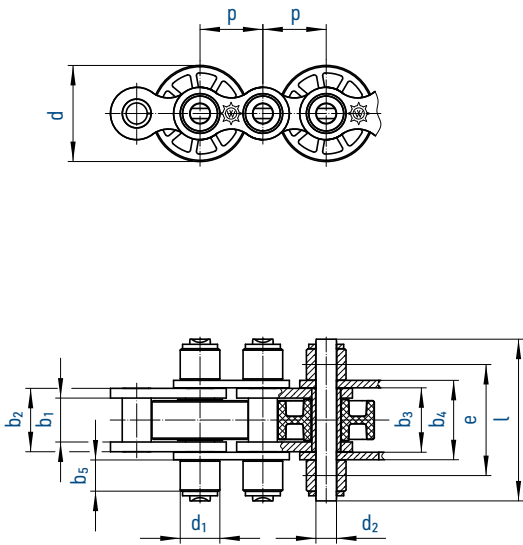
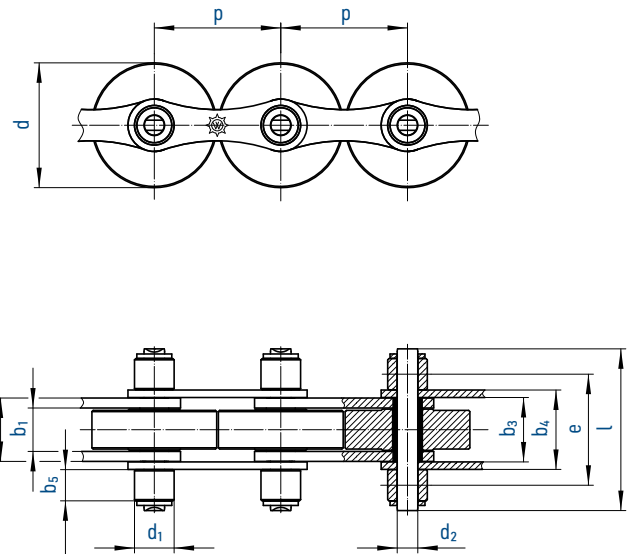

Design E

Double pitch roller chain Design L

Chain	Pitch	Design	Inner width	Inner link width	Width between over outer plates		Support roller Ø	Pin Ø	Transverse pitch	Plate height	Width over pin	Support roller width	Width over pin type I	Support roller width
					b ₃ min.	b ₄ max.								
No.	Ind.	mm	mm	mm	mm	mm	mm	mm	mm	mm	mm	mm	mm	mm
513 SF	19,050	E	11,68	15,62	15,80	20,0	12,00	5,72	31,50	16,1	48,0	11,5	43,0	9,0
548 SF	25,400	E	17,02	25,45	25,81	32,0	15,88	8,28	44,50	21,0	65,0	12,5	-	-
722 SF	38,100	L	11,68	15,62	15,80	20,0	12,00	5,72	31,50	16,1	48,0	11,5	-	-
728 SF	50,800	L	17,02	25,45	25,81	32,0	15,88	8,28	44,50	21,0	65,0	12,5	-	-
D 513 SF	19,050	D	11,68	15,62	15,80	20,0	12,07	5,72	52,00	16,1	68,0	11,5	-	-
D 548 SF	25,400	D	17,02	25,45	25,81	32,0	15,88	8,28	76,76	21,0	97,0	12,5	-	-
T 455 SF	9,525	T	5,72	8,53	-	-	6,35	3,28	20,48	8,2	34,0	-	-	-
T 513 SF	19,050	T	11,68	15,62	15,80	20,0	12,07	5,72	38,92	16,1	61,7	-	-	-
T 548 SF	25,400	T	17,02	25,45	25,81	32,0	15,88	8,28	63,76	21,0	99,9	-	-	-

Accumulator chains (stainless steel)

513 SF RF	19,050	E	11,68	15,62	15,80	20,0	12,00	5,72	31,50	16,1	48,0	11,5	43,0	9,0
548 SF RF	25,400	E	17,02	25,45	25,81	32,0	15,88	8,28	44,50	21,0	65,0	12,5	-	-
722 SF RF	38,100	L	11,68	15,62	15,80	20,0	12,00	5,72	31,50	16,1	48,0	11,5	-	-
728 SF RF	50,800	L	17,02	25,45	25,81	32,0	15,88	8,28	44,50	21,0	65,0	12,5	-	-
T 513 SF RF	19,050	T	11,68	15,62	-	-	12,07	5,72	38,92	16,1	61,7	-	-	-
T 548 SF RF	25,400	T	17,02	25,45	-	-	15,88	8,28	63,76	21,0	99,9	-	-	-

²⁷ Different from the drawing: No inner links in the middle strand! Roller width: 8,5 mm.

Sprockets are available for all accumulator chains!

Connecting links with securing circlips.

Our connecting links always have the same length l as the ordinary pins.

Temperature range: - 30 to 100°C for steel conveyor rollers

- 10 to 60°C for plastic conveyor rollers



Design D

Design T

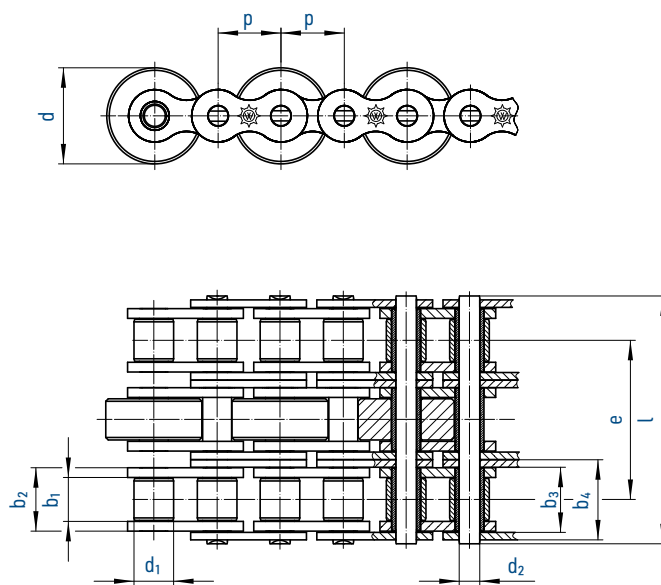
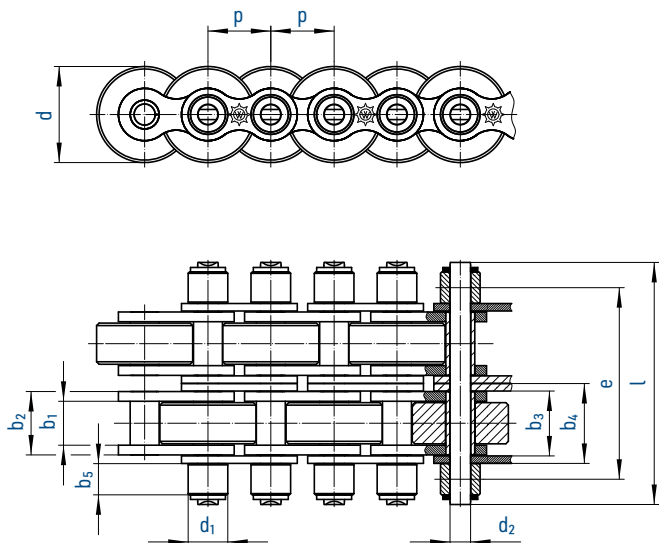

Width over pin type II l max. mm.	Support roller width b ₅ max. mm.	Conveyor rollers						Breaking load F _B min. kN	Maximum load per m conveyor chain with 10 m conveyor length	
		Designation for material			Diameter				Steel	Plastic
		Steel	PA 6.6	Vestamide	d	type I d	type II d			
40,0	7,5	SF	SFK	SFV	24,0	26,0	28,0	29,00	300	260
-	-	SF	SFK	SFV	38,5	-	-	60,00	600	500
-	-	SF	SFK	SFV	24,0	26,0	28,0	29,00	300	260
-	-	SF	SFK	SFV	38,5	40,0	50,0	60,00	600	500
-	-	SF	SFK	SFV	24,0	26,0	28,0	57,80	600	520
-	-	SF	SFK	SFV	38,5	-	-	120,00	1200	1000
-	-	SF	SFK	SFV	9,2	15,0	-	16,80	100	100
-	-	SF	SFK	SFV	24,0	26,0	28,0	60,00	600	260
-	-	SF	SFK	SFV	38,5	-	-	120,00	1200	500

Accumulator chains (stainless steel)

40,0	7,5	SF RF	SFK RF	SFV RF	24,0	26,0	28,0	18,50	200	200
-	-	SF RF	SFK RF	SFV RF	38,5	-	-	40,00	300	300
-	-	SF RF	SFK RF	SFV RF	24,0	26,0	28,0	18,50	200	200
-	-	SF RF	SFK RF	SFV RF	38,5	40,0	50,0	40,00	300	300
-	-	SF RF	SFK RF	SFV RF	24,0	26,0	28,0	31,45	400	400
-	-	SF RF	SFK RF	SFV RF	38,5	-	-	68,00	600	600

The load per m applies for 10 m conveyor distance per double chain strand. The load may be proportionally increased for shorter chain strands and must be proportionally decreased for longer conveyor distances: e.g. 5 m conveyor distance = double load, 20 m conveyor distance = half load.

Maximum conveyor distances 25 - 30 m. The installation of guide plates is recommended as of 15 m (see page 74).

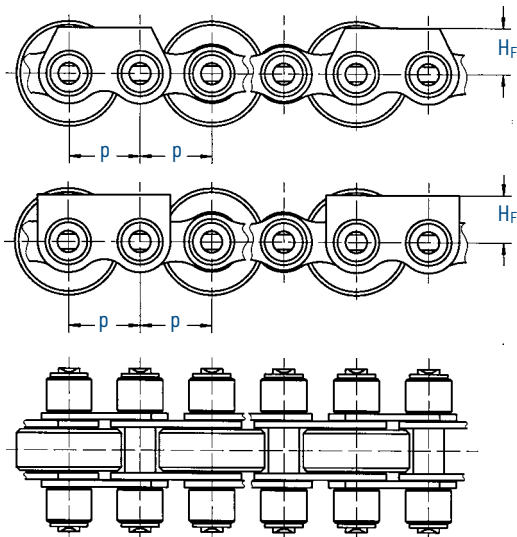

513 SF
548 SF

The guide plate distance is an even multiple of the pitch, e.g. $T = 4p$

Chain	p	H_F	
No.	mm	mm	mm
513 SF	19,05	10,7	$\pm 0,1$
548 SF	25,40	18,0	$\pm 0,1$

Design with guide plates

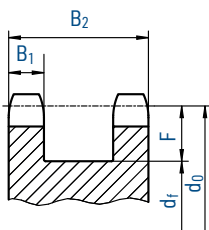
Axial profile of sprockets for accumulator chains



$$d_F = d_0 - 2F$$

Chain	B_1	B_2	F
No.	mm	mm	mm
T 455	5,2	25,7	8,0
513 SF	10,6	42,0	16,0
D 513 SF	10,6	62,6	16,0
T 513 SF	10,8	88,6	16,0
548 SF	12,0	56,5	22,0
D 548 SF	12,0	88,8	22,0
T 548 SF	15,8	79,6	22,0
722 SF	10,6	42,0	16,0
728 SF	12,0	56,6	27,0

Sprockets are available for all accumulator chains.

Chain guide for accumulator chains

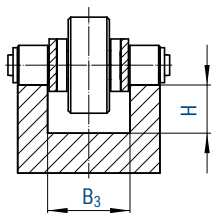

Chain	B_3	H
No.	mm	mm
513 SF	20,8	15,0
513 SFK	20,8	15,0
D 513 SF	40,5	15,0
548 SF	33,0	20,0
D 548 SF	66,0	20,0
722 SF	20,8	15,0
728 SF	33,0	27,0

Different designs, roller diameters and pin lengths are available on request

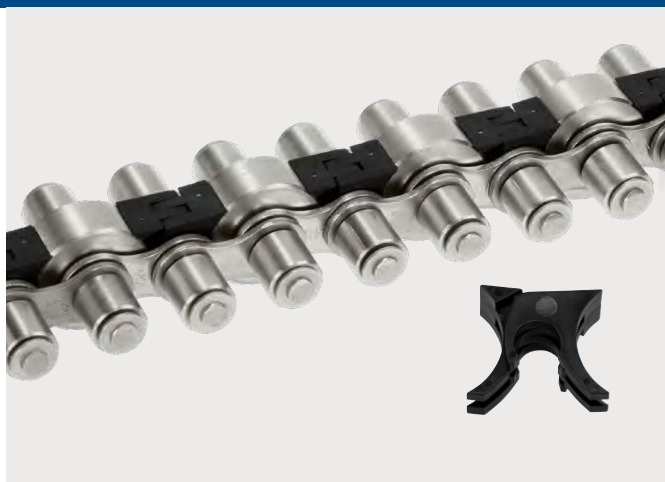

Accumulator chain with AFS-Clip



Omega drive

Accumulator chain AFS – optimal equipment and finger protection

- Prevents small parts from entering into gaps between conveyor rollers
- Increases operational safety
- Covers danger zone in chain deflection range as well
- Both-way deflections (e.g. with omega drives) still possible
- Can be supplied with different diameters and in various materials

Accumulator chains have a so-called conveyor roller on every other pitch. This is required for the transport of the material to be conveyed and ensures the smoothly running of the chain under the goods during accumulation without damaging them.

The chain link joint between the conveyor rollers constitutes a larger gap into which small parts might enter and then damage the chain or the entire system. Depending on the respective application area,

there is also the danger of fingers reaching into these gaps and thus causing injuries.

An accumulator chain with AFS clip ensures a trouble-free operation of conveyance and assembly systems and contributes considerably to operational safety according to effective machinery directives. For due to the flat design of the AFS clip the gap between the conveyor rollers is completely closed. The two-piece clip is mounted by snapping it onto the chain bushing of the inner link also covering the danger zone in the deflection range of the chain. Therefore both-way deflections, e.g. with omega drives, are still possible.

Depending on the respective application, conveyor rollers with different diameters made of various materials (steel, PA 6.6, PA 12 antistatic) can be supplied.

Accumulator chains can also be supplied in stainless steel, as maintenance-free MARATHON chains as well as in duplex or triplex designs.

AFS-Clips – Retrofitting for safety

For standard accumulator chains with conveyor roller diameters of 24 mm and 26 mm



The two-piece clip is mounted by simply snapping it onto the chain bushing of the inner link.

Due to the flat design of the AFS clip the construction-related gap between the conveyor rollers is completely closed. Hence equipment and finger protection is considerably increased.

Retrofitting of this innovative and easily mountable protective safety feature is possible for every standard accumulator chain with conveyor roller diameters of 24 mm and 26 mm. The two-piece clip is mounted by simply snapping it onto the chain bushing of the inner link. No tools are necessary since the pieces can easily be snapped directly onto the chain from the top. The correct position is guaran-

teed by a clear locking in place of the clip during mounting. Owing to its innovative hinge system it also covers the danger zone in the deflection range of the chain. Therefore both-way deflections, e.g. for omega drives, are possible.

Thus the wear-resistant AFS clips ensure a trouble-free operation of conveyance and assembly systems and contribute considerably to operational safety according to effective machinery directives.