

# uni Flex Plastic Chain

Series **uni 2800**

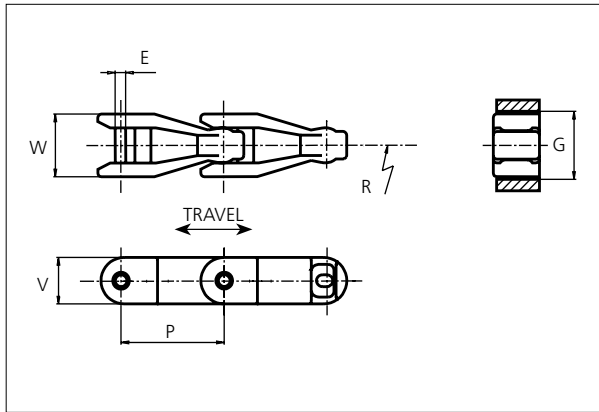

**uni Flex Plastic Chain**  
 Side flexing chain  
 Pitch: 82.5 mm (3.25 in)  
 Backflex radius:  
 75.0 mm (2.90 in)  
 Permissible tensile strength:  
 POM material:  
 6000 N (1349 lbf)  
  
 Standard shipping lengths:  
 boxes of 74 links  
 = 6.105 m (20.0 ft)

STANDARD

E		G		P		V	
mm	in	mm	in	mm	in	mm	in
9.5	0.37	54.0	2.13	82.5	3.25	37.3	1.47

All dimensions are for chains in POM material.

Width (W)		Material & color	Pin material	Weight		Min. radius (R)	
mm	in			kg/m	lb/ft	mm	in
53.5	2.11	POM-D <b>W</b>	<b>SS304</b>	1.6	1.09	500	19.69

Non standard material and color: See uni Material and Color Overview.

Non standard pin material: See uni Material and Color Overview.

SIDE FLEXING

PITCH 82.5 MM/3.25 IN

# uni Flex Plastic Chain

Series **uni 2800** Type **Tab**

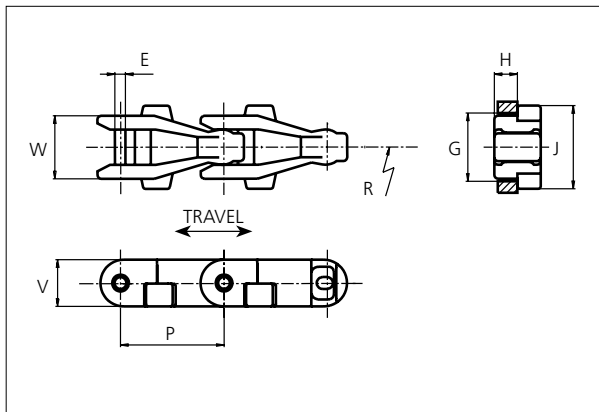

### uni Flex Plastic Chain

Side flexing chain  
 Pitch: 82.5 mm (3.25 in)  
 Backflex radius:  
 75.0 mm (2.90 in)  
 Permissible tensile strength:  
 POM material:  
 6000 N (1349 lbf)  
  
 Standard shipping lengths:  
 boxes of 74 links  
 = 6.105 m (20.0 ft)

STANDARD

E		G		H		J		P		V	
mm	in	mm	in	mm	in	mm	in	mm	in	mm	in
9.5	0.37	54.0	2.13	18.1	0.71	67.4	2.65	82.5	3.25	37.3	1.47

All dimensions are for chains in POM material.

Width (W)		Material & color	Pin material	Weight		Min. radius (R)	
mm	in			kg/m	lb/ft	mm	in
53.5	2.11	POM-D <b>W</b>	<b>SS304</b>	1.7	1.14	500	19.69

Non standard material and color: See uni Material and Color Overview.

Non standard pin material: See uni Material and Color Overview.

UNI FLEX PLASTIC CHAIN

PITCH 82.5 MM/3.25 IN

## Sprocket

No of teeth	Pitch diameter		Overall-diameter		Min. ø bore		Max. ø bore		Hub-diameter		Dimension A		Dimension B		 Machined PA6
	mm	in	mm	in	mm	in	mm	in	mm	in	mm	in	mm	in	
<b>Z6</b>	165.0	6.50	168.0	6.60	20.0	0.80	40.0	1.60	63.0	2.50	53.0	2.10	101.0	4.00	✓
<b>Z8</b>	215.6	8.49	224.0	8.80	20.0	0.80	50.0	2.00	73.5	2.90	81.1	3.20	126.3	5.00	✓
<b>Z10</b>	267.0	10.51	277.0	10.90	20.0	0.80	50.0	2.00	73.5	2.90	108.5	4.30	152.0	6.00	✓

### Machined sprocket

Non standard material and color:  
See uni Material and Color Overview.

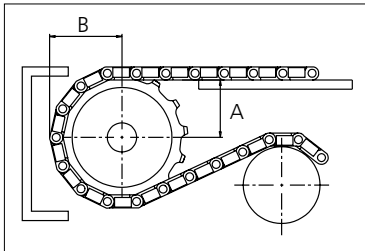

Please ensure that sufficient size shaft and keyway are chosen for corresponding load.

Other sprocket sizes are available upon request  
 Width of tooth: 15.0 mm/0.59 in  
 Width of sprocket: 42.3 mm/1.67 in  
 uni Retainer Rings: See uni Retainer Ring data sheet



Conveyor Belts



Seamless Belts

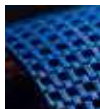

Modular Belts

This information is subject to alteration due to continuous development. uni-chains will not be held liable for the incorrect use of the above stated information. This information replaces previous information. All activities performed and services rendered by uni-chains are subject to general terms and conditions of sale and delivery, as applied by its operating companies.