

Slat Top Plastic Chain

Series **uni 440** Type **Tab**

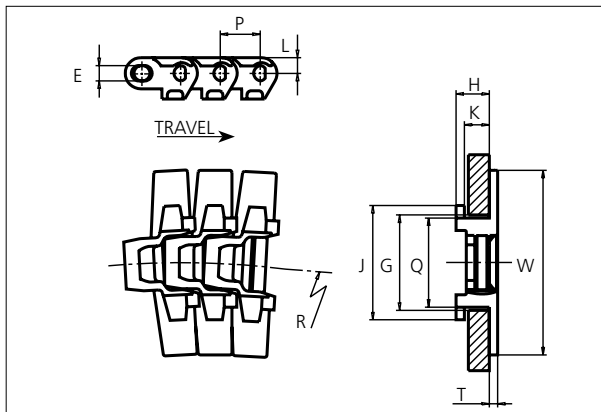

Slat Top Plastic Chain
 Side flexing chain
 Pitch: 19.1 mm (0.75 in)
 Backflex radius:
 12.5 mm (0.5 in)
 Permissible tensile strength:
 POM material:
 1100 N (247 lbf)

 Standard shipping lengths:
 boxes of 160 links
 = 3.048 m (10.0 ft)

E		G		H		J		K		L		P		Q		T	
mm	in	mm	in	mm	in	mm	in	mm	in	mm	in	mm	in	mm	in	mm	in
7.4	0.29	44.5	1.75	15.9	0.63	55.0	2.17	11.9	0.47	7.5	0.30	19.1	0.75	42.9	1.69	4.0	0.16

All dimensions are for chains in POM material.

	Width (W)		Material & color	Pin material	Weight		Min. radius (R)	
	mm	in			kg/m	lb/ft	mm	in
K250	63.5	2.50	POM-LF BR	SS304	1.2	0.81	175	6.89
K325	82.6	3.25	POM-LF BR	SS304	1.3	0.87	175	6.89
K350	88.9	3.50	POM-LF BR	SS304	1.3	0.87	175	6.89
K450	114.3	4.50	POM-LF BR	SS304	1.4	0.94	175	6.89
K750	190.5	7.50	POM-LF BR	SS304	1.6	1.07	175	6.89

Non standard material and color: See uni Material and Color Overview.

Non standard pin material: See uni Material and Color Overview.

STANDARD

SIDE FLEXING

PITCH 19.1 MM/0.75 IN

Sprocket

No of teeth	Pitch diameter		Overall diameter		Min. ϕ bore		Max. ϕ bore		Hub diameter		Dimension A		Dimension B		Machined  PAG
	mm	in	mm	in	mm	in	mm	in	mm	in	mm	in	mm	in	
Z9	55.8	2.20	57.0	2.20	10.0	0.40	25.0	1.00	37.0	1.50	29.8	1.20	35.6	1.40	✓
Z12	73.8	2.91	76.0	3.00	10.0	0.40	30.0	1.20	56.0	2.20	39.2	1.50	44.5	1.80	✓
Z20	122.1	4.81	125.3	4.90	18.0	0.70	70.0	2.80	105.0	4.10	63.8	2.50	68.6	2.70	✓

Non standard material and color:
See uni Material and Color Overview.

Machined sprocket

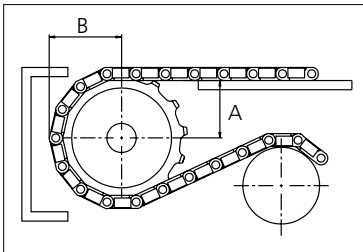

Please ensure that sufficient size shaft and keyway are chosen for corresponding load.

Other sprocket sizes are available upon request
Width of tooth: 15.8 mm/0.60 in
Width of sprocket: 25.0 mm/0.10 in
uni Retainer Rings: See uni Retainer Ring data sheet