

Slat Top Plastic Chain

Series **uni 820** Type -

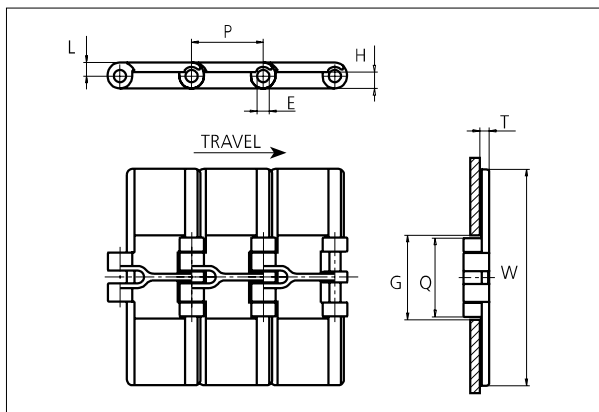

Slat Top Plastic Chain
 Straight running chain
 Pitch: 38.1 mm (1.50 in)
 Backflex radius: 75.0 mm (3.00 in)
 Permissible tensile strength:
 POM material: 2000 N (450 lbf)

 Delivery: 3.05 m (10 ft)
 No. of links/box: 80

STANDARD

E		G		H		L		P		Q		T	
mm	in	mm	in	mm	in	mm	in	mm	in	mm	in	mm	in
6.4	0.25	44.5	1.75	9.5	0.37	7.1	0.28	38.1	1.50	41.5	1.63	4.0	0.16

All dimensions are for chains in POM material.

	Width (W)		Material & color				Pin material	Weight		
	mm	in						kg/m	lb/ft	
K250	63.5	2.50	POM-LF BR B	POM-SLF DG			SS304	0.7	0.50	
K325	82.6	3.25	POM-D W G	POM-LF BR B	POM-SLF DG	PP-AR N	SS304	0.9	0.57	
			PBT-GR K	POM-EC K						
K350	88.9	3.50	POM-D G	POM-LF BR B			SS304	0.9	0.60	
K400	101.6	4.00	POM-D G	POM-LF BR B			SS304	1.0	0.64	
			POM-SLF DG							
K450	114.3	4.50	POM-D W G	POM-LF BR B			SS304	1.0	0.69	
K600	152.4	6.00	POM-D G	POM-LF BR B			SS304	1.3	0.84	
			POM-SLF DG							
K750	190.5	7.50	POM-D W G	POM-LF BR B	POM-SLF DG			SS304	1.5	0.99

Non standard material and color: See uni Material and Color Overview.

Non standard pin material: See uni Material and Color Overview.

STRAIGHT RUNNING

PITCH 38.1 MM/1.50 IN

Accessories

Rubber Top

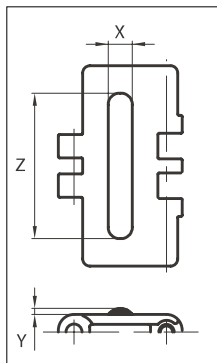

When ordering, please state the required distance between the Rubber Top.
 Other Non Standard rubber profiles:
 See uni Rubber Profile Overview.



Width	Link material	Rubber material	Z		X		Y	
			mm	in	mm	in	mm	in
K325	POM-LF BR	05 I	60	2.36	10	0.39	2.5	0.10
K350	POM-LF BR	05 I	60	2.36	10	0.39	2.5	0.10
K400	POM-LF BR	05 I	90	3.54	10	0.39	2.5	0.10
K450	POM-LF BR	05 I	105	4.13	10	0.39	2.5	0.10
K600	POM-LF BR	05 I	130	5.12	10	0.39	2.5	0.10
K750	POM-LF BR	05 I	170	6.69	10	0.39	2.5	0.10

Slat Top Plastic Chain

Series **uni 831** Type -

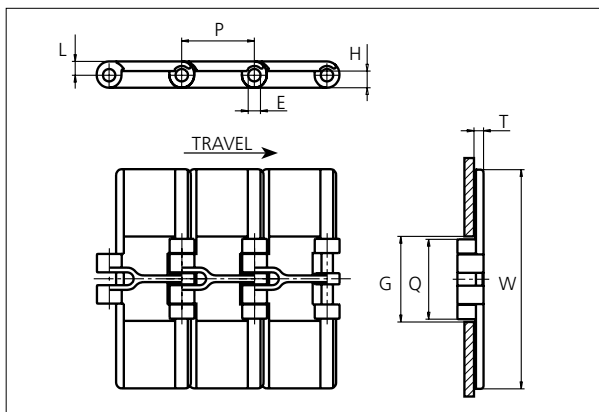

Slat Top Plastic Chain
 Straight running chain
 Pitch: 38.1 mm (1.50 in)
 Backflex radius:
 75.0 mm (3.00 in)
 Permissible tensile strength:
 POM material:
 2000 N (450 lbf)
 Standard shipping lengths:
 boxes of 80 links
 = 3.048 m (10.0 ft)

STANDARD

E		G		H		L		P		Q		T	
mm	in	mm	in	mm	in	mm	in	mm	in	mm	in	mm	in
6.4	0.25	44.5	1.75	8.5	0.33	7.1	0.28	38.1	1.50	41.5	1.63	5.0	0.20

All dimensions are for chains in POM material

	Width (W)		Material & color	Pin material	Weight	
	mm	in			kg/m	lb/ft
K250	63.5	2.50	-	-	-	-
K325	82.6	3.25	POM-LF BR POM-SLF G	SS304	1.0	0.67
K350	88.9	3.50	-	-	-	-
K400	101.6	4.00	POM-LF BR	SS304	1.2	0.81
K450	114.3	4.50	POM-LF BR	SS304	1.3	0.87
K600	152.4	6.00	POM-LF BR	SS304	1.6	1.05
K750	190.5	7.50	POM-LF BR	SS304	1.8	1.21

Non standard material and color: See uni Material and Color Overview.
 Non standard pin material: See uni Material and Color Overview.

STRAIGHT RUNNING

PITCH 38.1 MM/1.50 IN

Accessories

Rubber Top

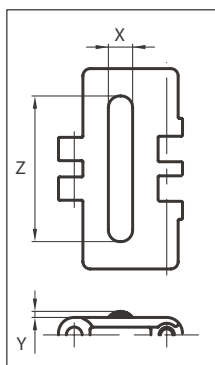
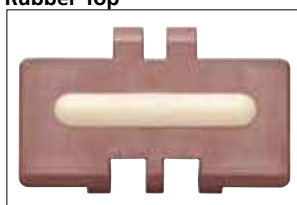

When ordering, please state the required distance between the Rubber Top.
 Other Non Standard rubber profiles:
 See uni Rubber Profile Overview.

Width	Link material	Rubber material	Z		X		Y	
			mm	in	mm	in	mm	in
K325	POM-LF BR	05 I	60	2.36	10	0.39	2.5	0.10
K350	POM-LF BR	05 I	60	2.36	10	0.39	2.5	0.10
K400	POM-LF BR	05 I	90	3.54	10	0.39	2.5	0.10
K450	POM-LF BR	05 I	105	4.13	10	0.39	2.5	0.10
K600	POM-LF BR	05 I	130	5.12	10	0.39	2.5	0.10
K750	POM-LF BR	05 I	170	6.69	10	0.39	2.5	0.10



Sprocket

No. of teeth	Pitch diameter		Overall diameter		Min. ø bore		Max. ø bore		Hub diameter		Dimension A		Dimension B		Molded PA66 LG	Molded Cast Iron	Machined PA66
	mm	in	mm	in	mm	in	mm	in	mm	in	mm	in	mm	in			
Z19	117.3	4.62	117.0	4.61	20.0	0.79	40.0	1.57	58.0	2.28	58.7	2.31	65.9	2.59	x	x	
Z21	129.2	5.09	130.0	5.12	20.0	0.79	40.0	1.57	58.0	2.28	65.0	2.56	71.8	2.83	x	x	
Z23	141.2	5.56	142.0	5.59	20.0	0.79	40.0	1.57	58.0	2.28	71.2	2.80	77.8	3.06	x	x	
Z25	153.2	6.03	155.0	6.10	20.0	0.79	40.0	1.57	58.0	2.28	77.4	3.05	83.8	3.30	x	x	
Z27	165.2	6.50	167.0	6.57	20.0	0.79	70.0	2.76	-	-	83.6	3.29	89.8	3.54		x	x
Z29	177.2	6.98	179.0	7.05	20.0	0.79	70.0	2.76	-	-	89.8	3.54	95.8	3.77		x	x
Z31	189.3	7.45	192.0	7.56	20.0	0.79	70.0	2.76	-	-	95.9	3.78	101.8	4.01		x	x

Two part sprocket

No. of teeth	Pitch diameter		Overall diameter		Min. ø bore		Max. ø bore		Hub diameter		Dimension A		Dimension B		Molded PA66 LG	Molded Cast Iron	Machined PA66
	mm	in	mm	in	mm	in	mm	in	mm	in	mm	in	mm	in			
Z19	117.3	4.62	117.0	4.31	20.0	0.79	40.0	1.57	58.0	2.28	58.7	2.31	65.9	2.59	x		
Z21	129.2	5.09	130.0	4.81	20.0	0.79	40.0	1.57	58.0	2.28	65.0	2.56	71.8	2.83	x		
Z23	141.2	5.56	142.0	5.30	20.0	0.79	40.0	1.57	58.0	2.28	71.2	2.80	77.8	3.06	x		
Z25	153.2	6.03	155.0	5.79	20.0	0.79	40.0	1.57	58.0	2.28	77.4	3.05	83.8	3.30	x		

Molded sprocket



Cast iron sprocket



Machined sprocket

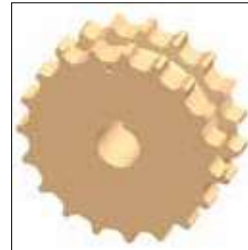

Two part sprocket



Non standard material and color:
See uni Material and Color Overview.

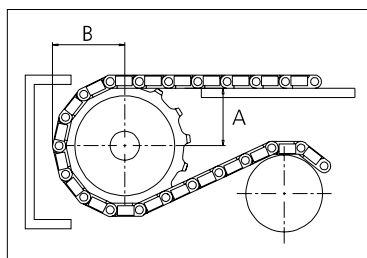

Please ensure that sufficient size shaft and keyway are chosen for corresponding load.

Other sprocket sizes are available upon request
 Width of tooth: 42.3 mm/1.70 in
 Width of sprocket: 42.3 mm/1.70 in
 uni Retainer Rings: See uni Retainer Ring data sheet
 uni Idler: See uni Idler data sheet