

**Paso de 19.05 mm (0.75 pulgadas)**



**uni Light – una banda única para aplicaciones ligeras**

La banda uni Light está diseñada para aplicaciones con un gran volumen de producción, acumulación y en las que es necesaria una transferencia suave entre transportadores.

**Las bandas uni Light mejoran el rendimiento en las siguientes industrias/aplicaciones:**

- Papel/pañuelos de papel, incluyendo separadores, mesas de acumulación y aplicaciones de envoltorio
- Bebidas, incluyendo depaletizadoras, paletizadoras, mesas de acumulación y líneas de aceleración
- Fabricación de latas, incluyendo paletizadoras, manipulado de masas y mesas de acumulación
- Manipulación de material
- Frutas y verduras, incluyendo mesas de inspección, transportadores de elevación e inclinados
- Panadería, incluyendo líneas de enfriamiento, manipulación de masas y transportadores de bandejas

**Características del producto y ventajas de funcionamiento:**

- Paso pequeño para aplicaciones a velocidad alta y transferencias pequeñas
- Mantenimiento fácil y menos tiempos muertos, gracias a su sistema único de cierre (lockpin)
- Aperturas únicas para un rendimiento alto (ej. 10% apertura para cerezas con rabo)
- Superficie lisa para una estabilidad alta (ej. producción de latas con cantos vivos)
- Sup. superior de goma de fricción alta, para aplicaciones de separación o transportadores inclinados

# Plastic Modular Belt

Series **uni Light** Type **C**

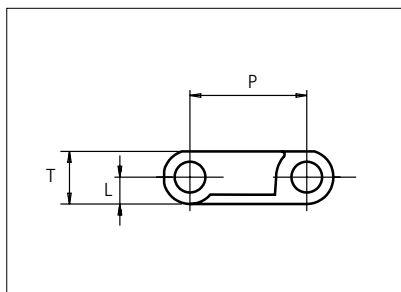

Straight running belt  
 Nominal pitch: 19.1 mm (0.75 in)  
 Surface type: Flat  
 Surface opening: Closed  
 Backflex radius: 25.0 mm (2.0 in)  
 Pin diameter: 5.0 mm (0.20 in)

Belt material & color	POM-LF <b>BR</b>	PP <b>W G K</b>	PP <b>B</b>	PA6 <b>K</b>													
Pin and lock material & color	PP <b>W</b>	PP <b>W</b>	PP <b>B</b>	PBT-GR <b>N</b> PP <b>G</b>													

Non standard material and color: See uni Material and Color Overview.

Alternative pin and lock materials: Pin: PE **W** PP **W** PA6.6 **N B** PBT **LG** SS304 PP **W** Lockpin: PBT **LG** PA6.6 **D N** PP **W B**

Belt width		Permissible tensile force (Belt/pin material)						Belt weight (Belt/pin material)						*Min. No. drive sprocket per shaft	Number of wear strips (Min. No.)	
		POM-LF/PP		PP/PP		PA6/PBT-GR		POM-LF/PP		PP/PP		PA6/PBT-GR			**Carry (pcs)	**Return (pcs)
mm	in	N	lbf	N	lbf	N	lbf	kg/m	lb/ft	kg/m	lb/ft	kg/m	lb/ft			
58	2.3	595	134	297	67	595	134	0.4	0.27	0.3	0.19	0.3	0.22	2	2	2
77	3.0	789	177	395	89	789	177	0.5	0.35	0.4	0.25	0.4	0.29	2	2	2
115	4.5	1175	264	587	132	1175	264	0.8	0.52	0.6	0.37	0.6	0.43	2	2	2
153	6.0	1572	353	786	177	1572	353	1.0	0.70	0.7	0.49	0.9	0.58	2	2	2
230	9.0	2355	529	1177	265	2355	529	1.6	1.05	1.1	0.74	1.3	0.86	2	2	2
306	12.1	3138	705	1569	353	3138	705	2.1	1.40	1.5	0.99	1.7	1.15	3	3	2
383	15.1	3921	881	1960	441	3921	881	2.6	1.75	1.8	1.23	2.1	1.44	3	3	2
459	18.1	4704	1057	2352	529	4704	1057	3.1	2.10	2.2	1.48	2.6	1.73	4	4	2
535	21.1	5486	1233	2743	617	5486	1233	3.6	2.45	2.6	1.73	3.0	2.01	4	4	2
612	24.1	6269	1409	3135	705	6269	1409	4.2	2.80	2.9	1.97	3.4	2.30	5	5	3
688	27.1	7052	1585	3526	793	7052	1585	4.7	3.14	3.3	2.22	3.9	2.59	5	5	3
764	30.1	7835	1761	3918	881	7835	1761	5.2	3.49	3.7	2.47	4.3	2.88	6	6	3
841	33.1	8618	1937	4309	969	8618	1937	5.7	3.84	4.0	2.71	4.7	3.16	6	6	3

Additional standard belt widths are available in steps of 76.4 mm (3.01 in.) Additional non-standard belt widths are available in steps of 19.1 mm (0.75 in.)

1910	75.2	19578	4401	9789	2201	19578	4401	13.0	8.73	9.2	6.16	10.7	7.19	13	13	7
------	------	-------	------	------	------	-------	------	------	------	-----	------	------	------	----	----	---

Additional standard belt widths are available in steps of 76.4 mm (3.01 in.) Additional non-standard belt widths are available in steps of 19.1 mm (0.75 in.)

2980	117.3	30545	6867	15273	3433	30545	6867	20.3	13.62	14.3	9.61	16.7	11.22	20	20	10
------	-------	-------	------	-------	------	-------	------	------	-------	------	------	------	-------	----	----	----

General belt tolerance is +0/-0.4% at 23°C/73°F and 50% RH. For exact belt width contact Customer Service. Non standard belt width on request.

The belt width in PA6 is 0.8 % wider than the belt width in the table

\*Max. Load per Drive Sprocket. Belt material: POM-LF 1250 N (281 lbf), PP 700 N (157 lbf), PA6 1250 N (281 lbf)

\*\*Max. Spacing between wear strips, Carry: 152 mm (6 in.) ; Return: 304 mm (12 in.)

= Single Link



STANDARD

STRAIGHT RUNNING

PITCH 19.1 MM/0.75 IN

# Plastic Modular Belt

Series **uni Light** Type **10%**

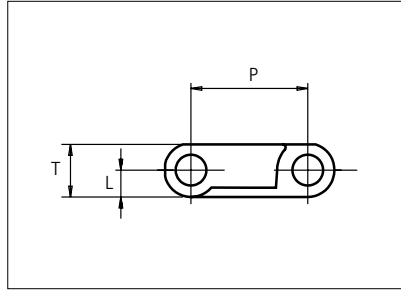

Straight running belt  
 Nominal pitch: 19.1 mm (0.75 in)  
 Surface type: Flat  
 Surface opening: 10%  
 Backflex radius: 25.0 mm (2.0 in)  
 Pin diameter: 5.0 mm (0.20 in)

<b>Belt material &amp; color</b>	POM-LF <b>BR</b>	<b>mm</b>	<b>in</b>		<b>mm</b>	<b>in</b>	
<b>Pin material &amp; color</b>	PP <b>W</b>	<b>P (Nominal)</b>	19.1	0.75	<b>T</b>	8.5	0.33
		<b>L</b>	4.3	0.17	-	-	-

Non standard material and color: See uni Material and Color Overview.

Alternative pin and lock materials: Pin: PE **W** PP **W** PA6.6 **N** **B** PBT **LG** SS304 **W** Lockpin: PBT **LG** PA6.6 **D** **N** PP **W** **B**

Belt width		Permissible tensile force (Belt/pin material)		Belt weight (Belt/pin material)		*Min. No. drive sprocket per shaft	Number of wear strips (Min. No.)	
		POM-LF/PP		POM-LF/PP			**Carry (pcs)	**Return (pcs)
mm	in	N	lbf	kg/m	lb/ft			
77	3.0	789	177	0.5	0.32	2	2	2
115	4.5	1175	264	0.7	0.48	2	2	2
153	6.0	1572	353	1.0	0.64	2	2	2
230	9.0	2355	529	1.4	0.96	2	2	2
306	12.1	3138	705	1.9	1.28	3	3	2
383	15.1	3921	881	2.4	1.59	3	3	2
459	18.1	4704	1057	2.8	1.91	4	4	2
535	21.1	5486	1233	3.3	2.23	4	4	2
612	24.1	6269	1409	3.8	2.55	5	5	3
688	27.1	7052	1585	4.3	2.87	5	5	3
764	30.1	7835	1761	4.7	3.19	6	6	3
841	33.1	8618	1937	5.2	3.50	6	6	3
917	36.1	9401	2113	5.7	3.82	7	7	4

Additional standard belt widths are available in steps of 76.4 mm (3.01 in.) Additional non-standard belt widths are available in steps of 19.1 mm (0.75 in.)

1910	75.2	19578	4401	11.8	7.96	13	13	7
------	------	-------	------	------	------	----	----	---

Additional standard belt widths are available in steps of 76.4 mm (3.01 in.) Additional non-standard belt widths are available in steps of 19.1 mm (0.75 in.)

2980	117.3	30545	6867	18.5	12.42	20	20	10
------	-------	-------	------	------	-------	----	----	----

General belt tolerance is +0/-0.4% at 23°C/73°F and 50% RH. For exact belt width contact Customer Service. Non standard belt width on request.

\*Max. Load per Drive Sprocket. Belt material: POM-LF 1250 N

\*\*Max. Spacing between wear strips, Carry: 152 mm (6 in); Return: 304 mm (12 in).

= Single Link



STANDARD

STRAIGHT RUNNING

PITCH 19.1 MM/0.75 IN

# Plastic Modular Belt

Series **uni Light** Type **22%**

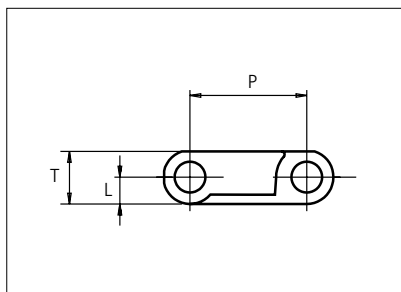
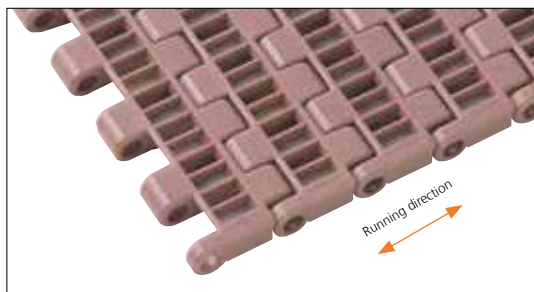

Straight running belt  
 Nominal pitch: 19.1 mm (0.75 in)  
 Surface type: Flat  
 Surface opening: 22%  
 Backflex radius: 25.0 mm (2.0 in)  
 Pin diameter: 5.0 mm (0.20 in)

Belt material & color	POM-LF <b>BR</b>	PP <b>G</b>	mm	in	mm	in		
			<b>P (Nominal)</b>	19.1	0.75	<b>T</b>	8.5	0.33
Pin material & color	PP <b>W</b>		<b>L</b>	4.3	0.17	-	-	-

Non standard material and color: See uni Material and Color Overview.

Alternative pin and lock materials: Pin: PE **W** PP **W** PA6.6 **N** **B** PBT **LG** SS304 **W** Lockpin: PBT **LG** PA6.6 **D** **N** PP **W** **B**

Belt width		Permissible tensile force (Belt/pin material)				Belt weight (Belt/pin material)				*Min. No. drive sprocket per shaft	Number of wear strips (Min. No.)	
		POM-LF/PP		PP/PP		POM-LF/PP		PP/PP			**Carry (pcs)	**Return (pcs)
mm	in	N	lbf	N	lbf	kg/m	lb/ft	kg/m	lb/ft			
77	3.0	789	177	395	89	0.4	0.29	0.3	0.21	2	2	2
115	4.5	1175	264	587	132	0.6	0.43	0.5	0.31	2	2	2
153	6.0	1572	353	786	177	0.9	0.58	0.6	0.41	2	2	2
230	9.0	2355	529	1177	265	1.3	0.86	0.9	0.62	2	2	2
306	12.1	3138	705	1569	353	1.7	1.15	1.2	0.82	3	3	2
383	15.1	3921	881	1960	441	2.1	1.44	1.5	1.03	3	3	2
459	18.1	4704	1057	2352	529	2.6	1.73	1.8	1.23	4	4	2
535	21.1	5486	1233	2743	617	3.0	2.01	2.1	1.44	4	4	2
612	24.1	6269	1409	3135	705	3.4	2.30	2.4	1.64	5	5	3
688	27.1	7052	1585	3526	793	3.9	2.59	2.8	1.85	5	5	3
764	30.1	7835	1761	3918	881	4.3	2.88	3.1	2.05	6	6	3
841	33.1	8618	1937	4309	969	4.7	3.16	3.4	2.26	6	6	3
917	36.1	9401	2113	4700	1057	5.1	3.45	3.7	2.47	7	7	4

Additional standard belt widths are available in steps of 76.4 mm (3.01 in.) Additional non-standard belt widths are available in steps of 19.1 mm (0.75 in.)

1910	75.2	19578	4401	9789	2201	10.7	7.19	7.6	5.13	13	13	7
------	------	-------	------	------	------	------	------	-----	------	----	----	---

Additional standard belt widths are available in steps of 76.4 mm (3.01 in.) Additional non-standard belt widths are available in steps of 19.1 mm (0.75 in.)

2980	117.3	30545	6867	15273	3433	16.7	11.22	11.9	8.01	20	20	10
------	-------	-------	------	-------	------	------	-------	------	------	----	----	----

General belt tolerance is +0/-0.4% at 23°C/73°F and 50% RH. For exact belt width contact Customer Service. Non standard belt width on request.

\*Max. Load per Drive Sprocket. Belt material: POM-LF 1250 N (281 lbf), PP 700 N (157 lbf)

\*\*Max. Spacing between wear strips, Carry: 152 mm (6 in); Return: 304 mm (12 in)

□ = Single Link



STANDARD

STRAIGHT RUNNING

PITCH 19.1 MM/0.75 IN

## Accessories

### Rubber Top

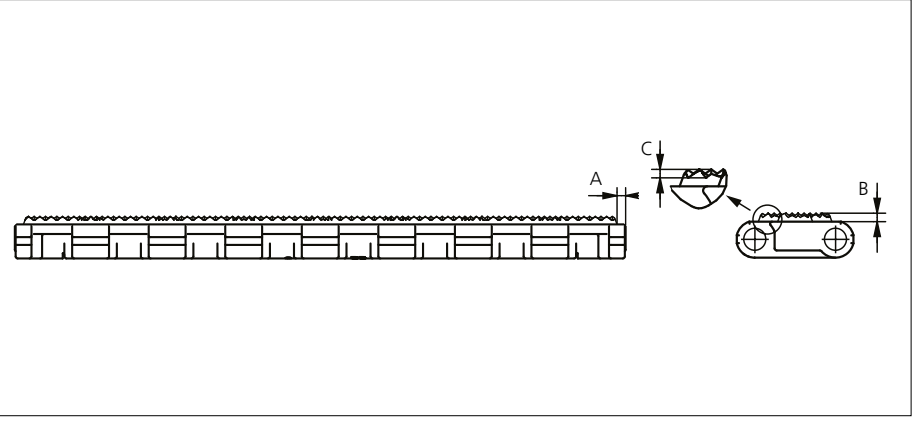

Type	Belt Material & color	Rubber Material & color	A		B		C		Link size	Width	
			mm	in	mm	in	mm	in		mm	in
NON STANDARD Flat	PP <b>K</b>	03 <b>K</b>	2.0	0.08	2.0	0.08	-	-	K300	76.0	2.99
STANDARD Rough							1.0	0.04		K600	114.0

Indent 15.0 mm (0.59 in) is only available in size 228.6 mm (9 in) and wider.

## Accessories

### Flight

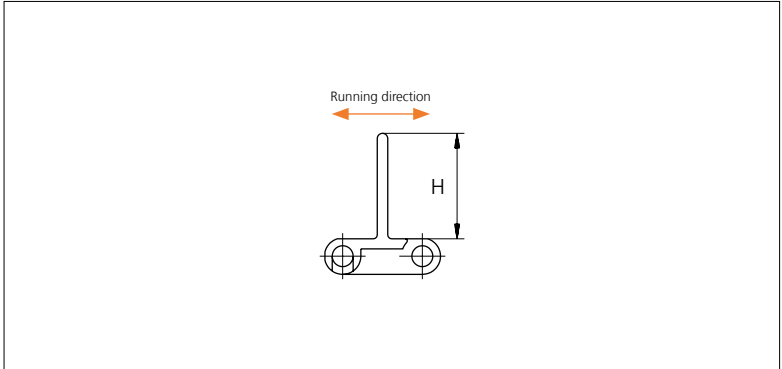
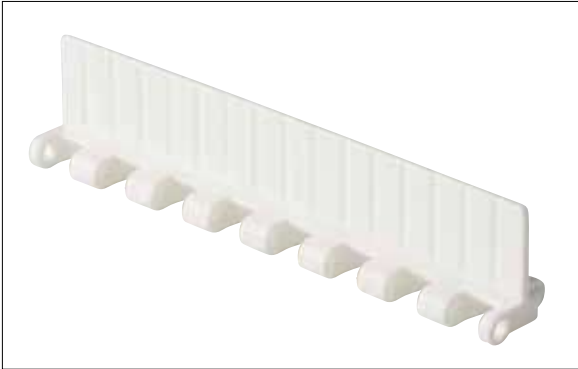

Type	Flight Material & color		H		Link size	Width		Indent	
			mm	in		mm	in	mm	in
Non Stick	PP-I	<b>W</b>	25.4	1.00	K300	76.4	3.01	0.0	0.00
	PP-I	<b>W</b> <b>G</b>							
Non Stick	PA6	<b>K</b>	25.4	1.00	K600	152.8	6.02	0.0	0.00
	04	<b>K</b>							
Non Stick	PP-I	<b>W</b> <b>G</b>	25.4	1.00	K600	152.8	6.02	15.0	0.59
Non Stick/Support Ribs	PP-I	<b>W</b>	25.4	1.00	K600	152.8	6.02	0.0	0.00
Non Stick/Support Ribs	PP-I	<b>W</b> <b>G</b>	50.8	2.00	K600	152.8	6.02	0.0	0.00
	PA6	<b>K</b>							
Non Stick/Support Ribs	PP-I	<b>G</b>	50.8	2.00	K600	152.8	6.02	15.0	0.59
	PA6	<b>K</b>							
Non Stick/Support Ribs	PP-I	<b>W</b> <b>G</b>	76.2	3.00	K600	152.8	6.02	0.0	0.00
Non Stick/Support Ribs	04	<b>K</b>	76.2	3.00	K600	152.8	6.02	0.0	0.00
Non Stick/Support Ribs	PP-I	<b>W</b> <b>G</b>	76.2	3.00	K600	152.8	6.02	15.0	0.59

Other Non Standard material and color: See uni Material and Color Overview.

## Accessories

### Side Guard

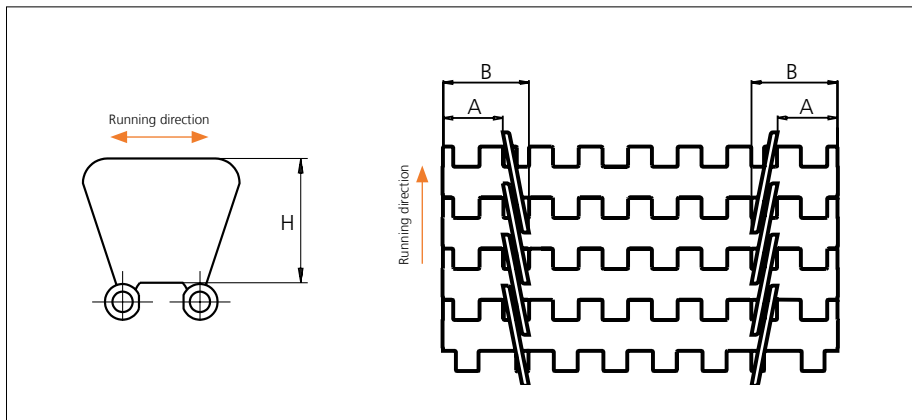

Type	Side Guard Material & color	H		A		B	
		mm	in	mm	in	mm	in
Closed	PP-I <b>W</b> <b>G</b>	31.4	1.24	15.0	0.59	25.0	0.98

Non Standard material and color: See uni Material and Color Overview.

## Accessories

### Tab

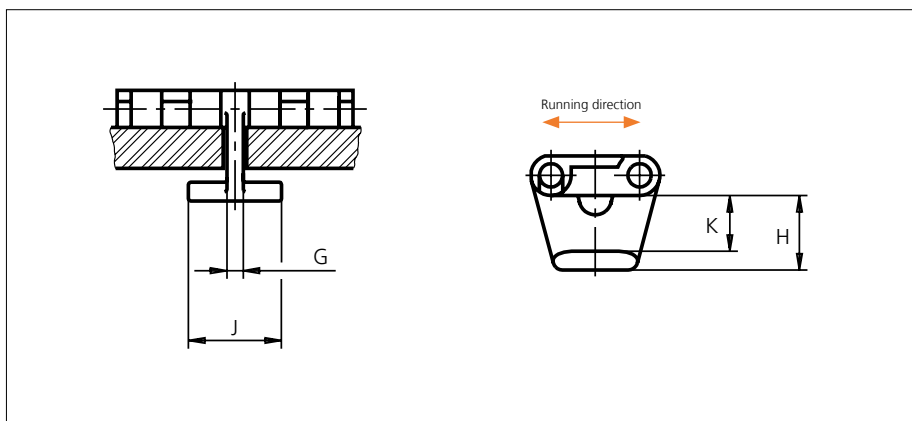

Type	Tab Material & color	G		J		K		H	
		mm	in	mm	in	mm	in	mm	in
Bottom Hold Down	POM-D <b>W</b>	3.5	0.14	20.0	0.79	11.7	0.46	15.9	0.63

Non Standard material and color: See uni Material and Color Overview.

## Sprocket

No of teeth	Bore size													Overall diameter		Pitch-diameter		Hub-diameter		A-dimension		B-dimension		Single row/Two way	Double row/Two way	Material	
	Pilot bore	in	0.75	0.78	0.98	1.00	1.18	1.25	1.50	1.57	2.36	2.50	3.54													mm	in
														mm	mm	mm	mm	mm	mm	mm	mm	mm	mm	mm	mm		
Z07	x		●	●										42.6	1.68	43.9	1.73	30.0	1.18	15.4	0.61	26.3	1.04	x		x	
Z10	x					●	●							61.7	2.43	61.6	2.43	45.0	1.77	25.0	0.98	35.2	1.39	x		x	
Z17	x				●	●	●	●	■	■				105.0	4.13	103.7	4.08	65.0	2.56	46.6	1.83	56.2	2.21	x		x	
Z24	x					●	●	●	■	■	●			147.2	5.80	146.0	5.75	70.0	2.76	68.0	2.68	77.3	3.04	x		x	
Z25	x						●	●	●	●	■	■		153.3	6.04	152.0	5.98	70.0	2.76	71.0	2.80	80.3	3.16	x		x	

■ Molded sprocket

● Molded sprocket

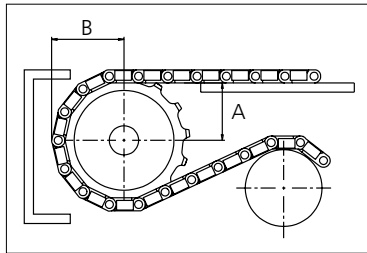
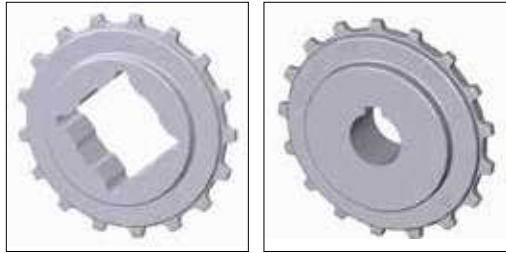

Other sprocket sizes are available upon request.  
 Two-part sprocket are available upon request.  
 Round bores are always delivered with keyway.  
 Other bore sizes are available upon request.  
 uni Retainer Rings: See uni Retainer Ring data sheet.  
 Width of tooth = 4.8 mm (0.19 in)  
 Width of sprocket = 25.0 mm (0.98 in)

Max load per sprocket shown does not take bore size into account.  
 Please also ensure that sufficient size shaft is chosen for corresponding load.

For correct sprocket position: See uni Assembly Instructions for uni Light.  
 For more detailed sprocket information, contact Customer Service.

Non standard material and color: See uni Material and Color Overview.