

SPANN-BOY® TS

Three tension pressure settings



with arc segment profile

Applications

- For applications with restricted free space beneath the chain. 40mm are sufficient.

Tensioning pressure

- Spann-Boy®TS has one light and one heavy pressure spring that can be released together or separately depending on the required tension pressure.

Attachment

- Installed next to the chain
- Bore holes in the housing

Attachment

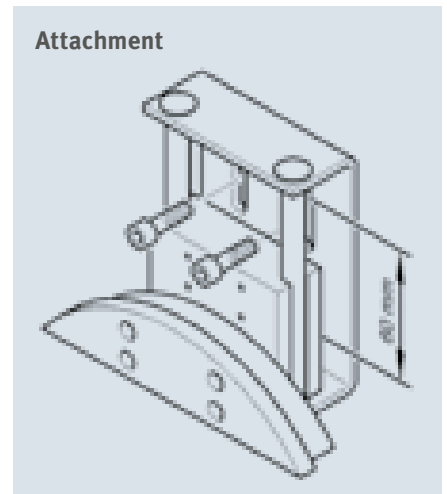

DIN 8187 chain no.	B	a	Standard design article no.	Stainless steel article no.	Availability
≤ 06B-1 (U Profile)	20	10.0	281 060 001	282 060 002	●
08B-1	20	16.5	281 060 003	282 060 004	●
10B-1	20	15.6	281 060 005	282 060 006	●
12B-1	20	14.8	281 060 007	282 060 008	●
06B-2	20	7.5	281 060 009	282 060 010	○
08B-2	32	15.2	281 060 011	282 060 012	●
10B-2	32	11.3	281 060 013	282 060 014	●
05B-3	20	7.4	281 060 015	282 060 016	○
06B-3	32	9.4	281 060 017	282 060 018	○

Special designs on request

● Stocked ○ Available within 10 days Dimensions in mm

