



MARATHON, the long distance chain that needs no relubrication:

- High-performance bearing joints
- Tensile strength according to WIPPERMANN standard
- Electrogalvanised surface for optimum protection
- Bushings with slight projection over plates



Advantages of the WIPPERMANN MARATHON chain:

- Up to 35 times longer wear life in comparison with other standard roller chains without lubrication
- Up to 5 times longer wear life than other maintenance-free chains
- No relubrication required
- Clean application with no soiling of machinery and transported goods
- Joint bushings made with a new type of sintered metal with high strength treated with a special lubricant
- Bushings longer than the width of the chain link with sliding contact to the outer plate
- The pins forming the joints with these bushings are made of alloyed hardened steel and are treated with a special coating. The resulting high-wearing coat guarantees an excellent sliding performance.
- Same tensile strength as with WIPPERMANN standard chains
- All MARATHON chains fit standard sprockets

Range of application for WIPPERMANN MARATHON chains:

- Temperatures from 0°C to +100°C
- With special lubrication from -30°C to +250°C (after consultation)
- Speeds of up to $v = 150$ m/min.
- Food industry
- Electrical industry
- Production of printed circuit boards (PCBs)
- Television industry
- Packing industry
- Paper processing
- Printing industry
- Bookbinding industry
- Textile industry
- Automotive industry
- All systems where relubrication is either not wanted, problematic or not possible at all.

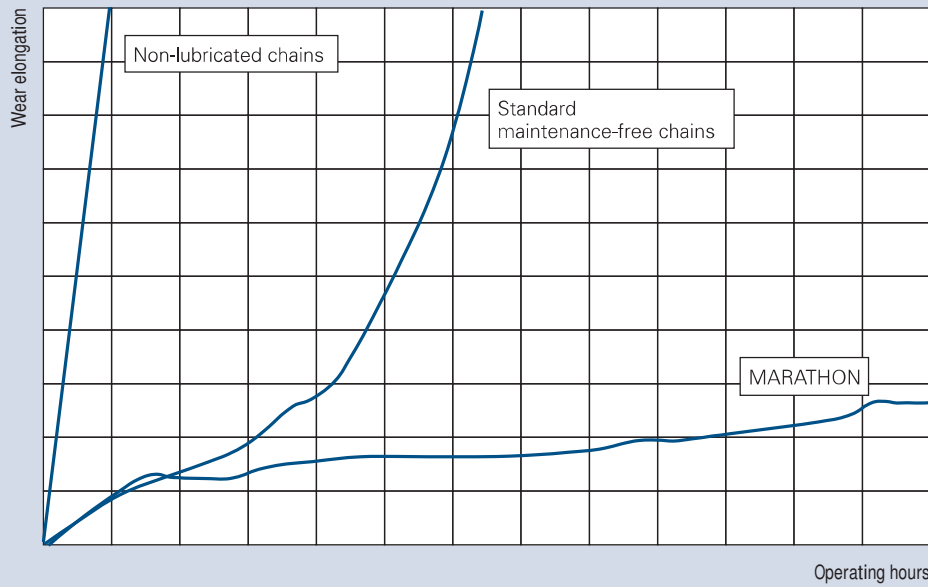

Results of long-term wear tests

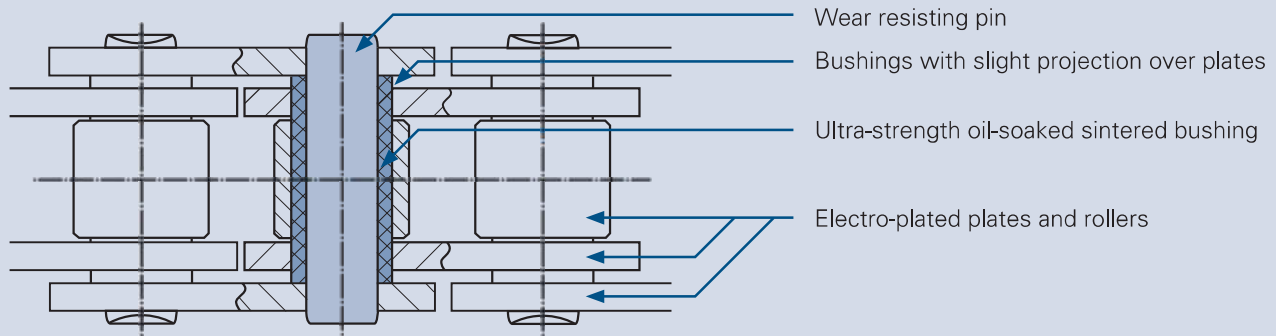

Type of test: Tensile test
 Object: 548 Marathon chain
 Test length: 5 links

Minimum tensile strength: 78,000 N
 Breaking point: Pins

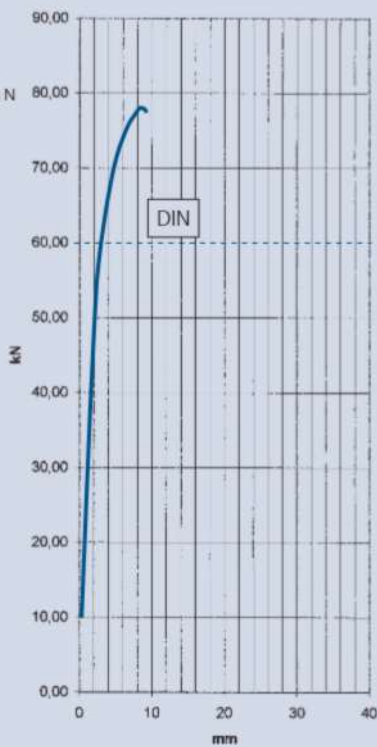

Force projection diagram



MARATHON - MAINTENANCE-FREE

Roller chains according to DIN 8187-1



Simplex chains

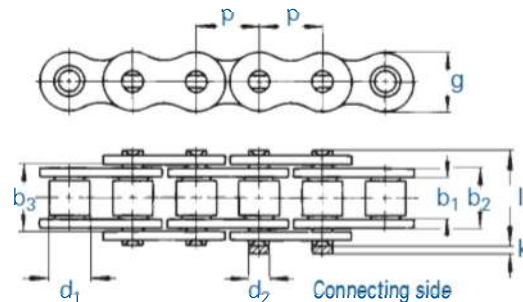

Duplex chains

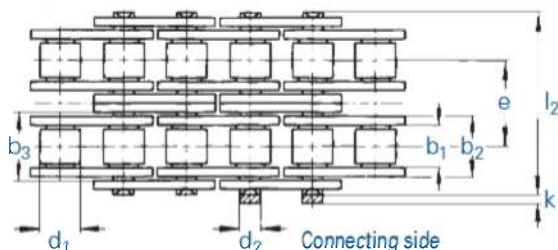

Triplex chains

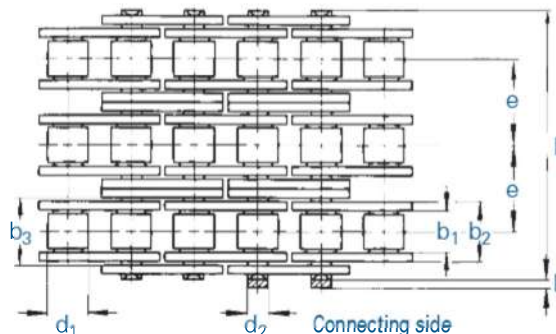

Chain		Pitch		Inner width	Inner link width	Outer plate width	Roller Ø	Pin Ø	Transverse pitch	Plate height	Projection over connecting link	Width over pin	Bearing area	Minimum tensile strength	Weight	Connecting links
No.		mm	inch	b ₁ min.	b ₂ max.	b ₃ min.	d ₁ max.	d ₂ max.	e	g max.	k max.	l max.	f	F _B min.	q ≈	No.
06 B-1 MA	¹	9,525	3/8	5,72	8,53	8,66	6,35	3,28	-	8,2	3,3	13,5	0,28	9,6	0,41	11,12,15
08 B-1 MA		12,7	1/2	7,75	11,30	11,43	8,51	4,45	-	11,8	3,9	17,0	0,50	18,6	0,70	11,12,15
10 B-1 MA		15,875	5/8	9,65	13,28	13,41	10,16	5,08	-	14,7	4,1	19,6	0,67	27,0	0,91	11,12,15
12 B-1 MA		19,05	3/4	11,68	15,62	15,75	12,07	5,72	-	16,1	4,6	22,7	0,89	31,0	1,18	11,12,15
16 B-1 MA		25,4	1	17,02	25,40	25,60	15,88	8,28	-	21,0	5,4	36,1	2,10	72,0	2,68	11,111,12
552 MA		30,0	-	17,02	25,40		15,88	8,28	-	21,0	5,4	36,1	2,10	72,0	2,50	11,111,12
20 B-1 MA		31,75	1 1/4	19,56	29,00	29,20	19,05	10,19	-	26,4	6,1	43,2	2,96	105,0	3,50	111,12
24 B-1 MA		38,1	1 1/2	25,40	37,90	38,20	25,40	14,63	-	33,4	6,6	53,4	5,54	180,0	6,80	111,12
06 B-2 MA	¹	9,525	3/8	5,72	8,53	8,66	6,35	3,28	10,24	8,2	3,3	23,8	0,56	17,4	0,78	11,12,15
08 B-2 MA		12,7	1/2	7,75	11,30	11,43	8,51	4,45	13,92	11,8	3,9	31,0	1,01	37,0	1,36	11,12,15
10 B-2 MA		15,875	5/8	9,65	13,28	13,41	10,16	5,08	16,59	14,7	4,1	36,2	1,34	54,0	1,82	11,12,15
12 B-2 MA		19,05	3/4	11,68	15,62	15,75	12,07	5,72	19,46	16,1	4,6	42,2	1,79	63,0	2,38	11,12,15
16 B-2 MA		25,4	1	17,02	25,40	25,60	15,88	8,28	31,88	21,0	5,4	68,0	4,21	140,0	5,30	11,111,12
20 B-2 MA		31,75	1 1/4	19,56	25,40	29,20	19,05	10,19	36,45	26,4	6,1	79,0	5,91	210,0	7,30	111,12
24 B-2 MA		38,1	1 1/2	25,40	37,90	38,20	25,40	14,63	48,36	33,4	6,6	101,0	11,09	360,0	13,40	111,12
06 B-3 MA	¹	9,525	3/8	5,72	8,53	8,66	6,35	3,28	10,24	8,2	3,3	34,0	0,81	24,9	1,18	11,12,15
08 B-3 MA		12,7	1/2	7,75	11,30	11,43	8,51	4,45	13,92	11,8	3,9	44,9	1,51	56,0	2,01	11,12,15
10 B-3 MA		15,875	5/8	9,65	13,28	13,41	10,16	5,08	16,59	14,7	4,1	52,8	2,02	80,0	2,70	11,12,15
12 B-3 MA		19,05	3/4	11,68	15,62	15,75	12,07	5,72	19,46	16,1	4,6	61,7	2,68	94,0	3,12	11,12,15
16 B-3 MA		25,4	1	17,02	25,40	25,60	15,88	8,28	31,88	21,0	5,4	99,9	6,31	211,0	7,50	11,111,12
20 B-3 MA		31,75	1 1/4	19,56	29,00	29,20	19,05	10,19	36,45	26,4	6,1	116,0	8,87	300,0	10,60	111,12
24 B-3 MA		38,1	1 1/2	25,40	37,90	38,20	25,40	14,63	48,36	33,4	6,6	150,0	16,63	523,0	20,00	111,12

¹ with straight side plates

Standard sprockets can be used for these chains.

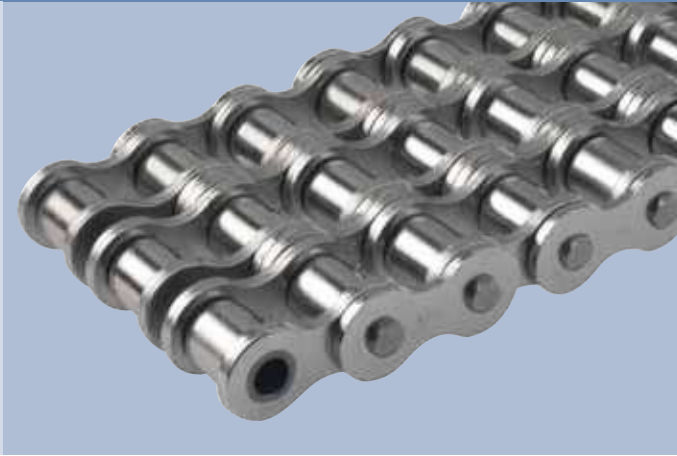

Simplex chains

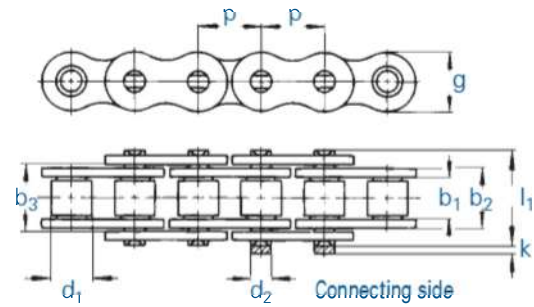

Duplex chains

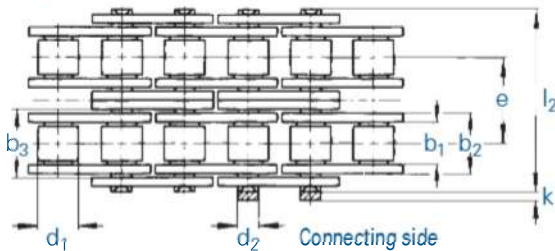

Triplex chains

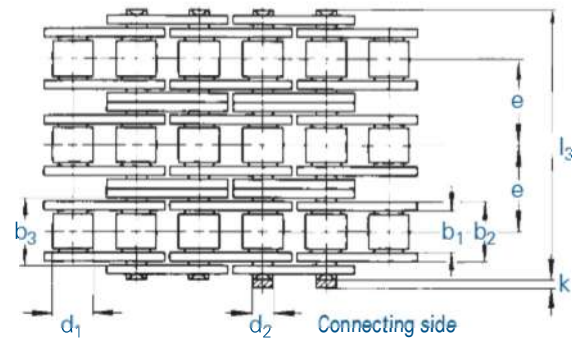

Chain		Pitch		Inner width	Inner link width	Outer plate width	Roller \varnothing	Pin \varnothing	Transverse pitch	Plate height	Projection over connecting link	Width over pin	Bearing area	Minimum tensile strength F_B	Weight	Connecting links
		p		b_1 min.	b_2 max.	b_3 min.	d_1 max.	d_2 max.	e	g max.	k max.	l max.	f	F_B min.	q \approx	No.
No.	Ind.	mm	inch	mm	mm	mm	mm	mm	mm	mm	mm	mm	cm ²	kN	kg/m	No.
08 A-1 MA		12,7	1/2	7,85	11,15	11,28	7,95	3,96	-	12,0	3,9	17,8	0,44	16,5	0,60	11,12,15
10 A-1 MA		15,875	5/8	9,40	13,80	13,93	10,16	5,08	-	15,0	4,1	21,8	0,70	30,0	1,01	11,12,15
12 A-1 MA		19,05	3/4	12,57	17,70	17,85	11,91	5,94	-	18,0	4,6	26,9	1,05	40,0	1,58	11,111,12,15
16 A-1 MA		25,4	1	15,75	22,50	22,70	15,88	7,92	-	24,1	5,4	33,5	1,78	69,0	2,36	11,111,12,15
20 A-1 MA		31,75	1 1/4	18,90	27,40	27,60	19,05	9,53	-	30,1	6,1	41,1	2,61	92,5	3,80	111,12
24 A-1 MA		38,1	1 1/2	25,22	35,30	35,60	22,23	11,10	-	36,2	6,6	50,8	3,92	139,0	5,40	111,12
08 A-2 MA		12,7	1/2	7,85	11,15	11,28	7,95	3,96	14,38	12,0	3,9	32,3	0,88	29,7	1,20	11,12,15
10 A-2 MA		15,875	5/8	9,40	13,80	13,93	10,16	5,08	18,11	15,0	4,1	39,9	1,40	62,0	1,78	11,12,15
12 A-2 MA		19,05	3/4	12,57	17,70	17,85	11,91	5,94	22,78	18,0	4,6	49,8	2,10	76,0	3,15	11,111,12,15
16 A-2 MA		25,4	1	15,75	22,50	22,70	15,88	7,92	29,29	24,1	5,4	62,7	3,56	135,0	4,90	11,111,12,15
20 A-2 MA		31,75	1 1/4	18,90	27,40	27,60	19,05	9,53	35,76	30,1	6,1	77,0	5,22	205,0	7,60	111,12
24 A-2 MA		38,1	1 1/2	25,22	35,30	35,60	22,23	11,10	45,44	36,2	6,6	96,3	7,84	290,0	10,80	111,12
08 A-3 MA		12,7	1/2	7,85	11,15	11,28	7,95	3,96	14,38	12,0	3,9	46,7	1,32	41,2	1,80	11,12,15
10 A-3 MA		15,875	5/8	9,40	13,80	13,93	10,16	5,08	18,11	15,0	4,1	57,9	2,10	88,0	3,02	11,12,15
12 A-3 MA		19,05	3/4	12,57	17,70	17,85	11,91	5,94	22,78	18,0	4,6	72,6	3,15	105,0	4,70	11,111,12,15
16 A-3 MA		25,4	1	15,75	22,50	22,70	15,88	7,92	29,29	24,1	5,4	91,7	5,35	193,0	7,50	11,111,12,15
20 A-3 MA		31,75	1 1/4	18,90	27,40	27,60	19,05	9,53	35,76	30,1	6,1	113,0	7,83	305,0	11,20	111,12
24 A-3 MA		38,1	1 1/2	25,22	35,30	35,60	22,23	11,10	45,44	36,2	6,6	141,0	11,76	410,0	16,10	111,12

Sprockets on request.



MARATHON - MAINTENANCE-FREE

Roller chains type series GL (straight plates)



Simplex chains

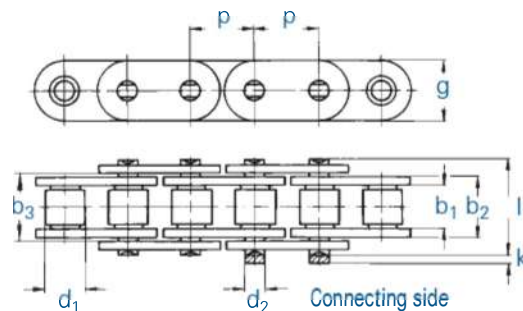

Duplex chains

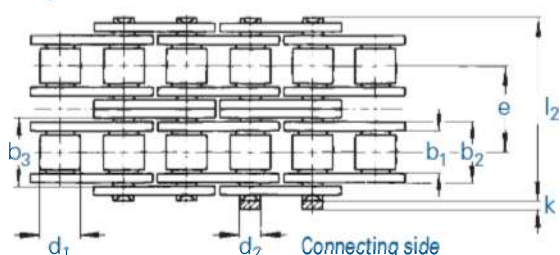

Triplex chains

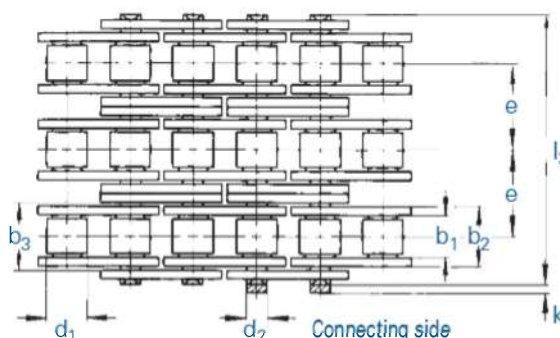

Chain		Pitch		Inner width	Inner link width	Outer plate width	Roller Ø	Pin Ø	Transverse pitch	Plate height	Projection over connecting link	Width over pin	Bearing area	Minimum tensile strength	Weight	Connecting links	
No.		Ind.	mm	inch	b ₁ min.	b ₂ max.	b ₃ min.	d ₁ max.	d ₂ max.	e	g max.	k max.	l max.	f	F _B min.	q ≈	No.
455 GL MA			9,525	3/8	5,72	8,53	8,66	6,35	3,28	-	8,2	3,3	13,5	0,28	9,6	0,41	4,7,11,12,15
462 GL MA			12,7	1/2	7,75	11,30	11,43	8,51	4,45	-	11,5	3,9	17,0	0,50	18,6	0,78	4,7,11,12
501 GL MA			15,875	5/8	9,65	13,28	13,41	10,16	5,08	-	14,2	4,1	19,6	0,67	27,0	1,03	4,7,11
513 GL MA			19,05	3/4	11,68	15,62	15,75	12,07	5,72	-	15,5	4,6	22,7	0,89	31,0	1,29	4,7,11,12
548 GL MA			25,4	1	17,02	25,40	25,60	15,88	8,28	-	24,0	5,4	36,1	2,10	72,0	3,29	4,7,11
548 GLS MA			25,4	1	17,02	25,40	25,60	15,88	8,28	-	21,0	5,4	36,1	2,10	72,0	2,90	4,7,11,12
563 GL MA			31,75	1 1/4	19,56	29,00	29,20	19,05	10,19	-	26,4	6,1	43,2	2,95	105,0	4,13	4,7,11,12
596 GL MA			38,1	1 1/2	25,40	37,90	38,20	25,40	14,63	-	33,4	6,6	53,4	5,54	180,0	7,34	4,7,11,12
455 GL-2MA			9,525	3/8	5,72	8,53	8,66	6,35	3,28	10,24	8,2	3,3	23,8	0,56	17,4	0,86	4,7,11,12,15
462 GL-2MA			12,7	1/2	7,75	11,30	11,43	8,51	4,45	13,92	11,5	3,9	31,0	1,01	37,0	1,50	4,7,11,12
501 GL-2MA			15,875	5/8	9,65	13,28	13,41	10,16	5,08	16,59	14,2	4,1	36,2	1,34	54,0	2,00	4,7,11
513 GL-2MA			19,05	3/4	11,68	15,62	15,75	12,07	5,72	19,46	15,5	4,6	42,2	1,79	63,0	2,62	4,7,11,12
548 GL-2MA			25,4	1	17,02	25,40	25,60	15,88	8,28	31,88	24,0	5,4	68,0	4,21	140,0	5,83	4,7,11
563 GL-2MA			31,75	1 1/4	19,56	29,00	29,20	19,05	10,19	36,45	26,4	6,1	79,0	5,81	210,0	8,03	4,7,11,12
596 GL-2MA			38,1	1 1/2	25,40	37,92	38,20	25,40	14,63	48,36	33,4	6,6	101,0	11,09	360,0	14,47	4,7,11,12
455 GL-3MA			9,525	3/8	5,72	8,53	8,66	6,35	3,28	10,24	8,2	3,3	34,0	0,81	24,9	1,30	4,7,11,12,15
462 GL-3MA			12,7	1/2	7,75	11,30	11,43	8,51	4,45	13,92	11,5	3,9	44,9	1,51	56,0	2,21	4,7,11,12
501 GL-3MA			15,875	5/8	9,65	13,28	13,41	10,16	5,08	16,59	14,2	4,1	52,8	2,02	80,0	2,97	4,7,11
513 GL-3MA			19,05	3/4	11,68	15,62	15,75	12,07	5,72	19,46	15,5	4,6	61,7	2,68	94,0	3,43	4,7,11,12
548 GL-3MA			25,4	1	17,02	25,40	25,60	15,88	8,28	31,88	24,0	5,4	99,9	6,31	211,0	8,25	4,7,11
563 GL-3MA			31,75	1 1/4	19,56	29,00	29,20	19,05	10,19	36,45	26,4	6,1	116,0	8,87	300,0	11,66	4,7,11,12
596 GL-3MA			38,1	1 1/2	25,40	37,90	38,20	25,40	14,63	48,36	33,4	6,6	150,0	16,63	523,0	22,00	4,7,11,12

Sprockets on request.

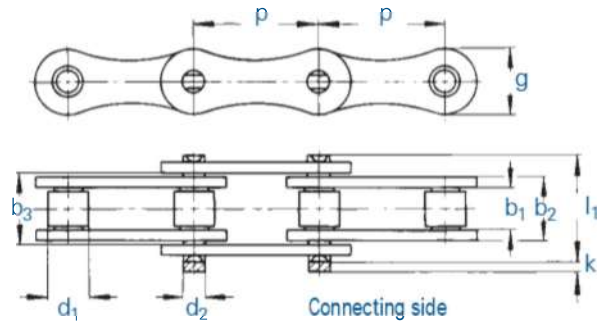

Chain		Pitch		Inner width	Inner link width	Outer plate width	Roller Ø	Pin Ø	Plate height	Projection over connecting link	Width over pin	Bearing area	Minimum tensile strength	Weight
⚙️		p		b ₁ min.	b ₂ max.	b ₃ min.	d ₁ max.	d ₂ max.	g max.	k max.	l ₁ max.	f	F _B min.	q ≈
No.	Ind.	mm	inch	mm	mm	mm	mm	mm	mm	mm	mm	cm ²	kN	kg/m
208 B MA		25,4	1	7,75	11,30	11,43	8,51	4,45	11,8	3,9	17,0	0,50	18,0	0,48
210 B MA		31,75	1 ¼	9,65	13,28	13,40	10,16	5,08	14,7	4,1	19,6	0,67	22,4	0,55
212 B MA		38,1	1 ½	11,68	15,62	15,75	12,07	5,72	16,1	4,6	22,7	0,89	29,0	0,80
216 B MA		50,8	2	17,02	25,40	25,60	15,88	8,28	21,0	5,4	36,1	2,10	60,0	1,74
220 B MA		63,5	2 ½	19,56	29,00	29,20	19,05	10,19	28,0	6,1	43,2	2,96	95,0	2,55

Sprockets for double pitch roller chains can be used for these chains.

Connecting links: According to DIN (...)



Nr. 4 (B)
Inner link



Nr. 7 (A)
Outer link
(to be riveted)



Nr. 111 (S)
Connecting link with cottared pin



Nr. 208 (B)
for chain No. 713 with spring clip (E)



Nr. 12 (L)
Single cranked link



Design E

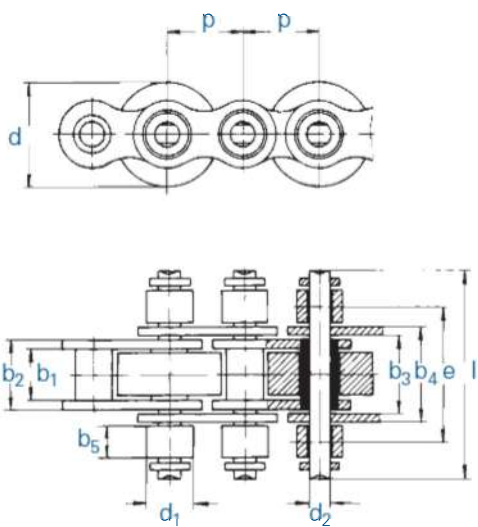

Double pitch chain Design L

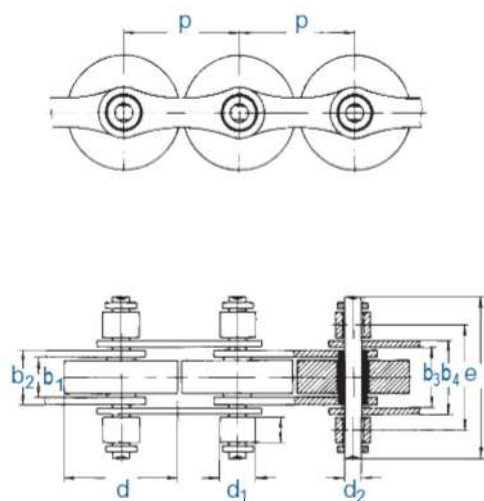

Chain	Pitch		Inner width	Inner link width	Width between over outer plates		Support roller Ø	Pin Ø	Transverse pitch	Plate height	Width over pin	Support roller width	Width over pin Type I	Support roller width	
	p	Design			b ₃ min.	b ₄ max.									d ₁
No.	Ind.	mm	mm	mm	mm	mm	mm	mm	mm	mm	mm	mm	mm	mm	
513 SF MA		19,05	E	11,68	15,62	15,80	20,0	12,00	5,72	31,50	16,1	48,0	11,5	43,0	9,0
548 SF MA		25,4	E	17,02	25,45	25,81	32,0	15,88	8,28	44,50	21,0	65,0	12,5	-	-
722 SF MA		38,1	L	11,68	15,62	15,80	20,0	12,00	5,72	31,50	16,1	48,0	11,5	-	-
728 SF MA		50,8	L	17,02	25,45	25,81	32,0	15,88	8,28	44,50	21,0	65,0	12,5	-	-
D 513 SF MA		19,05	D	11,68	15,62	15,80	20,0	12,07	5,72	52,00	16,1	68,0	11,5	-	-
D 548 SF MA		25,4	D	17,02	25,45	25,81	32,0	15,88	8,28	76,76	21,0	97,0	12,5	-	-
T 513 SF MA		19,05	T	11,68	15,62	15,80	20,0	12,07	5,72	38,92	16,1	61,7	-	-	-
T 548 SF MA		25,4	T	17,02	25,45	25,81	32,0	15,88	8,28	63,76	21,0	99,9	-	-	-

Sprockets are available for all accumulator chains!

Connecting links with securing circlips.

Our connecting links always have the same length I as the ordinary pins.

Temperature range: - 30 to 100°C for steel conveyor rollers

- 10 to 60°C for plastic conveyor rollers

For information on AFS clips for optimal equipment and finger protection see page 59.



Design D

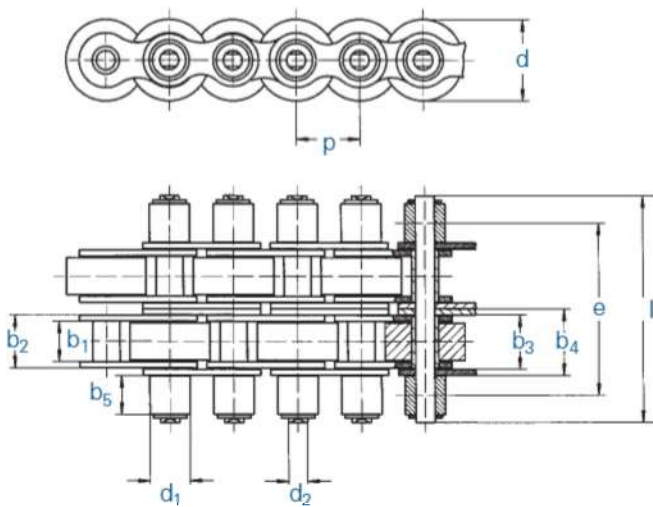

Design T

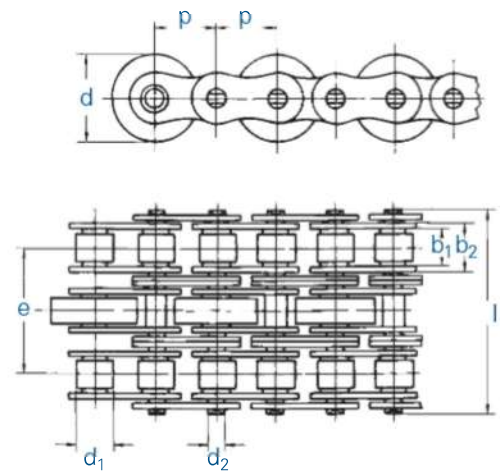

Width over pin Type II	Support roller width	Conveyor rollers						Minimum tensile strength F_B min.	Maximum load per m conveyor chain with 10 m conveyor length	
		Designation for material			Diameter				Steel	Plastic
I max.	b_5 max.	Steel	PA 6.6	Vestamide	d	Type I d	Type II d			
mm.	mm				mm	mm	mm	kN	kg	kg
40,0	7,5	SF	SFK	SFV	24,0	26,0	28,0	29,0	300	260
-	-	SF	SFK	SFV	38,5	-	-	60,0	600	500
-	-	SF	SFK	SFV	24,0	26,0	28,0	29,0	300	260
-	-	SF	SFK	SFV	38,5	40,0	50,0	60,0	600	500
-	-	SF	SFK	SFV	24,0	26,0	28,0	57,8	600	520
-	-	SF	SFK	SFV	38,5	-	-	120,0	1200	1000
-	-	SF	SFK	SFV	24,0	26,0	28,0	60,0	600	260
-	-	SF	SFK	SFV	38,5	-	-	120,0	1200	500

The load per m applies for 10 m conveyor length per double chain strand. The load may be proportionally increased for shorter chain lengths and must be proportionally decreased for longer conveyor distances: e.g. 5 m conveyor distance = double load, 20 m conveyor distance = half load.

Maximum conveyor distances 25 - 30 m. The installation of guide plates is recommended as of 15 m.



Simplex chains

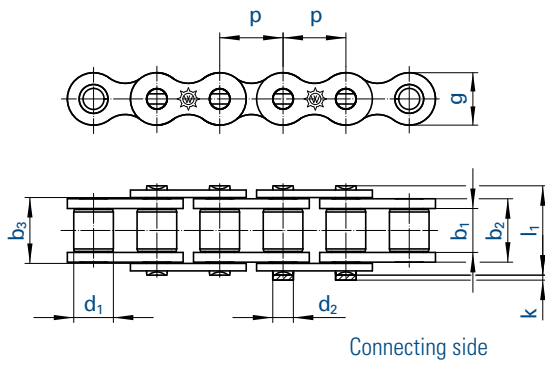

Simplex chains (Type GL)

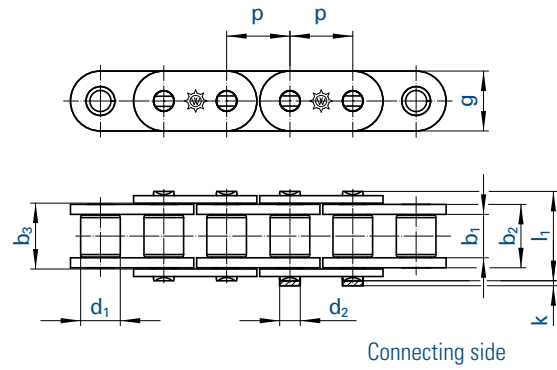

Duplex chains

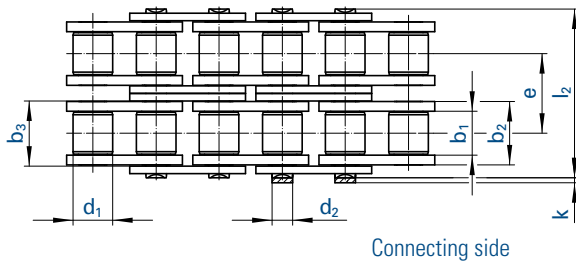

Triplex chains

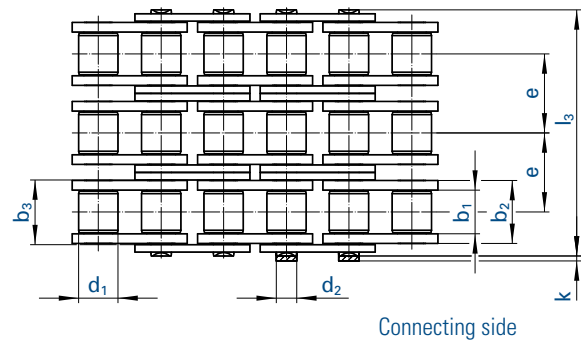

Chain		ISO	Pitch		Inner width	Inner link width	Outer plate width	Roller Ø	Pin Ø	Transverse pitch	Plate height	Projection over connecting link	Width over pin	Bearing area	Breaking load	Weight	Connecting links
No.	Ind.		mm	inch	b ₁ min.	b ₂ max.	b ₃ min.	d ₁ max.	d ₂ max.	e	g max.	k max.	l max.	f	F _B min.	q ≈	No.
462 RF MA	08 B-1	12,700	1/2	7,75	11,30	11,43	8,51	4,45	-	11,8	3,9	17,0	0,50	12,00	0,70	4,7,11,12,15	
501 RF MA	10 B-1	15,875	5/8	9,65	13,28	13,41	10,16	5,08	-	14,7	4,1	19,6	0,67	14,50	0,91	4,7,11,12,15	
513 RF MA	12 B-1	19,050	3/4	11,68	15,62	15,75	12,07	5,72	-	16,1	4,6	22,7	0,89	18,50	1,18	4,7,11,12,15	
548 RF MA	16 B-1	25,400	1	17,02	25,40	25,60	15,88	8,28	-	21,0	5,4	36,1	2,10	40,00	2,50	4,7,11,12	
D 462 RF MA	08 B-2	12,700	1/2	7,75	11,30	11,43	8,51	4,45	13,92	11,8	3,9	31,0	1,01	20,40	1,36	4,7,11,12,15	
D 501 RF MA	10 B-2	15,875	5/8	9,65	13,28	13,41	10,16	5,08	16,59	14,7	4,1	36,2	1,34	24,65	1,82	4,7,11,12,15	
D 513 RF MA	12 B-2	19,050	3/4	11,68	15,62	15,75	12,07	5,72	19,46	16,1	4,6	42,2	1,79	31,45	2,38	4,7,11,12,15	
D 548 RF MA	16 B-2	25,400	1	17,02	25,40	25,60	15,88	8,28	31,88	21,0	5,4	68,0	4,21	68,00	5,10	4,7,11,12	
T 462 RF MA	08 B-3	12,700	1/2	7,75	11,30	11,43	8,51	4,45	13,92	11,8	3,9	44,9	1,51	32,50	2,01	4,7,11,12,15	
T 501 RF MA	10 B-3	15,875	5/8	9,65	13,28	13,41	10,16	5,08	16,59	14,7	4,1	52,8	2,02	39,00	2,70	4,7,11,12,15	
T 513 RF MA	12 B-3	19,050	3/4	11,68	15,62	15,75	12,07	5,72	19,46	16,1	4,6	61,7	2,68	49,50	3,12	4,7,11,12,15	
T 548 RF MA	16 B-3	25,400	1	17,02	25,40	25,60	15,88	8,28	31,88	21,0	5,4	99,9	6,31	108,00	7,50	4,7,11,12	

Can also be supplied with attachments, straight plates (type series GL) and as double pitch roller chains (dimensions according to ISO 1275). Chains 548 available as type series GLs with plate height g = 21 mm (max.) and as type series GL with g = 24 mm (max.). Sprockets on request.

Connecting links: According to ISO (...)



No. 4 (B)

Inner link

No. 7 (A)

Outer link
(to be riveted)

No. 11 (E)

Spring clip
connecting link

No. 111 (S)

Connecting link
with cottered pin

No. 12 (L)

Single
cranked link

No. 15 (C)

Double
cranked link